

# 三菱工業用ミシン部品カタログ

## MITSUBISHI

### Industrial Sewing Machine Parts Catalog

**Model**  
**PLY-0418F**  
**PLY-0418**

目次	INDEX	Page
1. 全体構成	Construction .....	1
2. 面板関係	Fase plate .....	2 ~ 6
3. 頭部関係	Head .....	7 ~ 11
4. 大押え機構	Main clamp mechanism .....	12 ~ 20
5. 三角メス機構	Tab knife mechanism .....	21 ~ 27
6. 本体機構	Frame mechanism .....	28 ~ 36
7. スタッカー機構	Stacker mechanism .....	37 ~ 40
8. エアーシリンダー機構	Air cylinder mechanism .....	41 ~ 43
9. 油圧機構	Hydraulic mechanism .....	44 ~ 45
10. 電気関係	Electlic mechanism .....	46 ~ 48

 **三菱電機株式会社**

PH-001A 198207

三井物産株式会社

INNOVATION

三井物産株式会社

三井物産株式会社

全体構図  
Construction

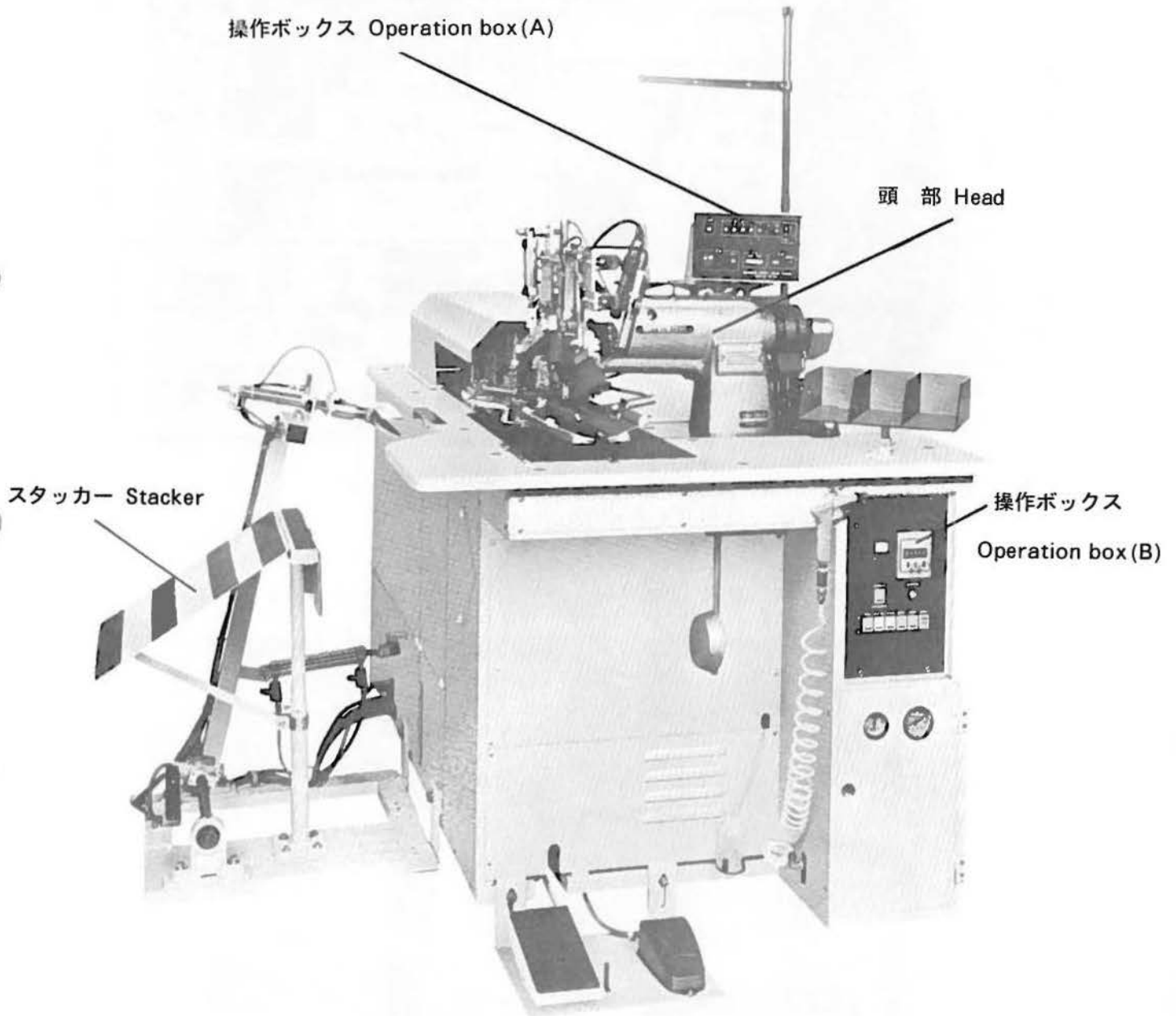

面板關係 (F)  
Fase plate

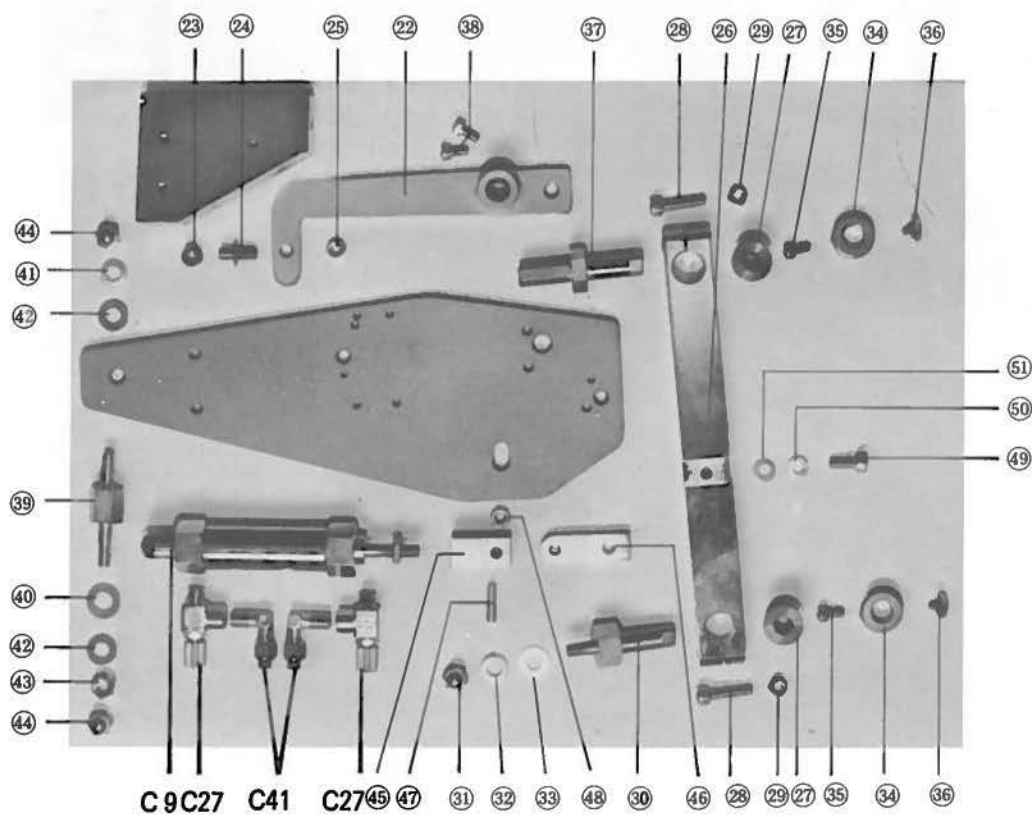
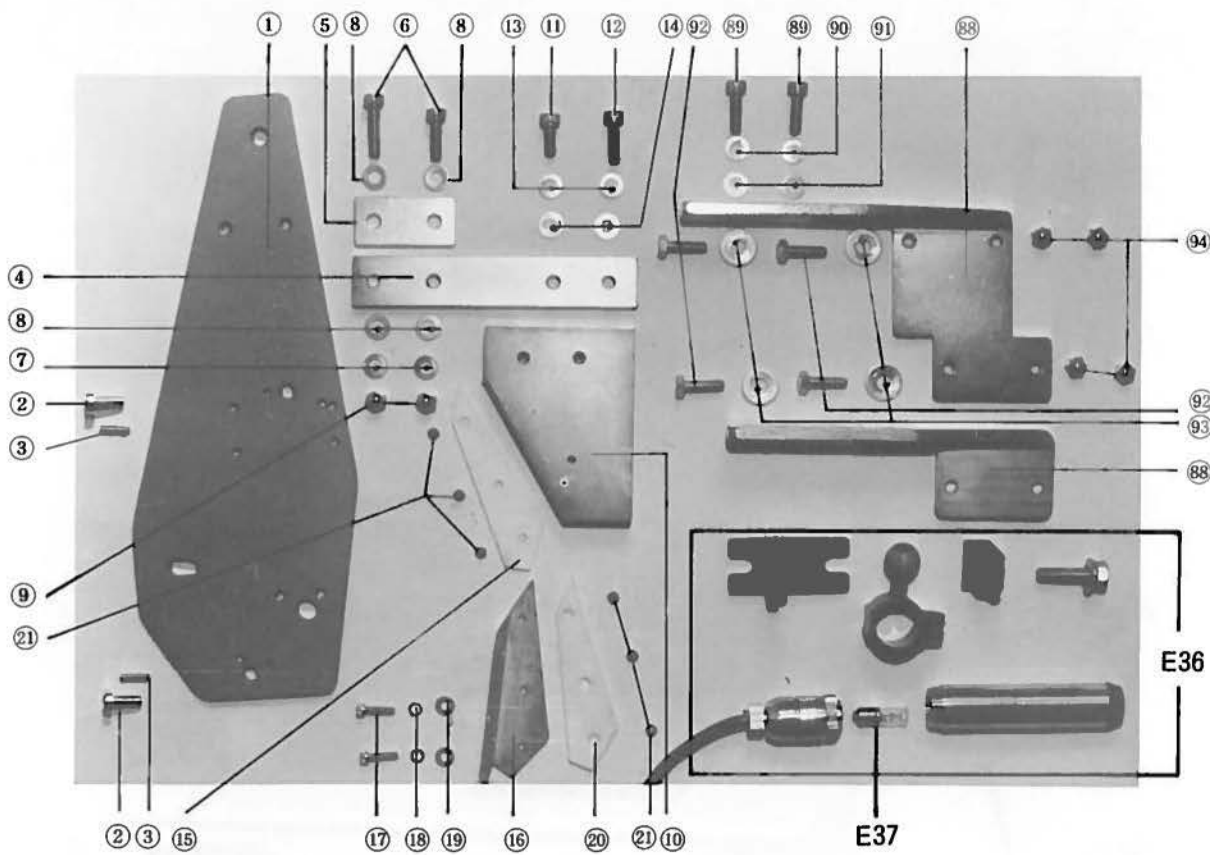

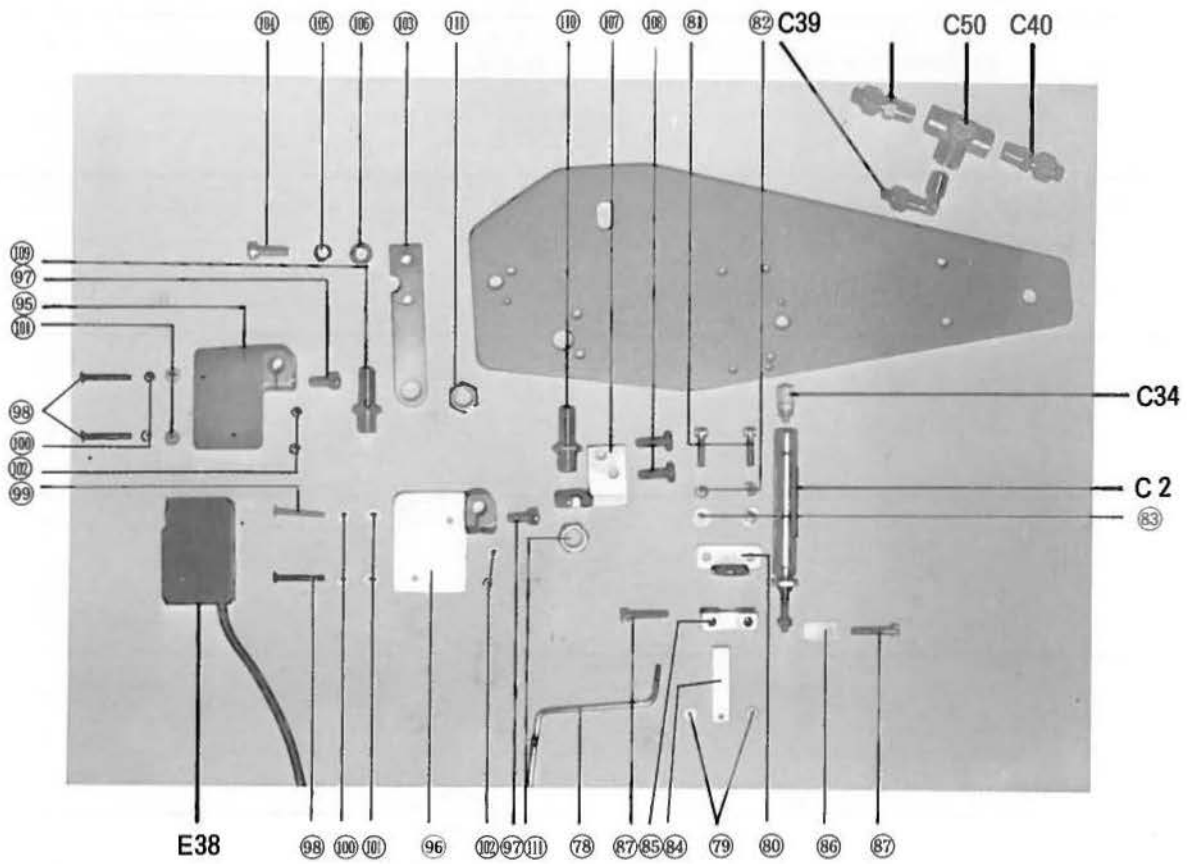
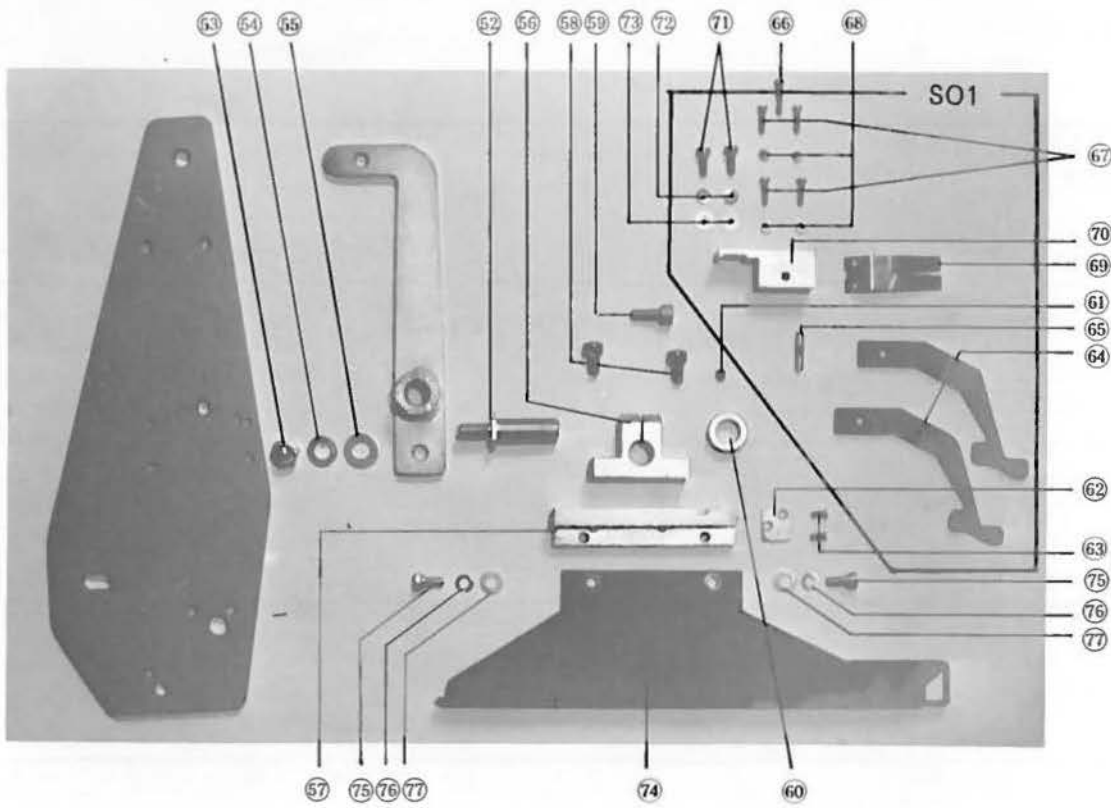

Fig. No.	部品番号 Parts. No.	部 品 名	Description	個・台 Amt. Req.	共通部品 Common Parts			
F 1	1001	面板	Face plate	1				
F 2	SM01	丸平ネジ	Screw (for Fig.1)	2				
F 3	P310	ノックピン	Nock pin	2				
F 4	1002	T型案内取付板	Set plate	1				
F 5	1002-1	“ スペーサー	Spacer	1				
F 6	M625	止めネジ	Screw (for Fig.4)	2				
F 7	SW06	スプリングワッシャー	Spring washer	2				
F 8	W006	ワッシャー	Washer	4				
F 9	NK06	ナット	Nut	2				
F 10	1003	T型案内ベース	Guide base	1				
F 11	M615	止めネジ	Screw (for Fig.10)	1				
F 12	M620	“	“ ( “ )	1				
F 13	SW06	スプリングワッシャー	Spring washer	2				
F 14	W006	ワッシャー	Washer	2				
F 15	1003-1	T型案内ベーススラスト板	Thrust plate (for Fig.10)	1				
F 16	1030	T型案内振れ止め	Vibration stoper	1				
F 17	M410	止めネジ	Screw (for Fig.16)	2				
F 18	SW04	スプリングワッシャー	Spring washer	2				
F 19	W004	ワッシャー	Washer	2				
F 20	1030-1	T型案内振れ止めスラスト板	Thrust plate (for Fig.16)	1				
F 21	IN18	丸皿ネジ	Screw (for Fig.15,20)	6				
F 22	1004	T型案内腕	Guide rod	1				
F 23	1004-1	ローラー	Roller	1				
F 24	1004-2	ピンネジ	Pin screw	1				
F 25	1004-3	ナット	Nut	1				
F 26	1006	T型駆動腕	Driving rod	1				
F 27	1006-1	T型駆動腕メタル	Bushing	2				
F 28	M625	止めネジ	Screw	2				
F 29	N006	ナット	Nut	2				
F 30	1007	T型駆動腕支え6角ピンネジ	Pin screw	1				
F 31	NK08	ナット	Nut	1				
F 32	SW08	スプリングワッシャー	Spring washer	1				
F 33	W008	ワッシャー	Washer	1				
F 34	1007-1	T型駆動腕当てカラー	Collar	2				
F 35	M510	止めネジ	Screw (for Fig.34)	2				
F 36	SM02	丸平ネジ	Screw	2				
F 37	1008	T型案内腕支え6角ピン	Pin	1				
F 38	M510	止めネジ	Screw (for Fig.22)	2				
F 39	1005	T型シリンダー支え6角ピンネジ	Cylinder set pin screw	1				
F 40	WBSP8	ワッシャー	Washer	1				
F 41	SW08	スプリングワッシャー	Spring washer	1				
F 42	W008	ワッシャー	Washer	2				
F 43	N008	ナット	Nut	1				
F 44	NK08	“	“	2				
F 45	1009	T型シリンダー先端金具	Cylinder supporting bracket	2				
F 46	1010	“ 連結板	Connecting plate	1				
F 47	1011	“ ピンネジ	Pin screw	1				
F 48	N006	ナット	Nut	1				
F 49	M615	止めネジ	Screw (for Fig.46)	1				
F 50	SW06	スプリングワッシャー	Spring washer	1				
F 51	W006	ワッシャー	Washer	1				
F 52	1021	T型取付台支えピンネジ	Pin screw	1				
F 53	NK08	ナット	Nut	1				
F 54	SW08	スプリングワッシャー	Spring washer	1				
F 55	W008	ワッシャー	Washer	1				

Fig. No.	部品番号 Parts. No.	部 品 名	Description	個・台 Amt. Req.	共通部品 Common Parts			
F56	1020-2	T型取付台 (上)	Set base (upper)	1				
F57	1020-1	" (下)	" (lower)	1				
F58	M610	止めネジ	Screw (for Fig.56)	2				
F59	M615	"	" (for Fig.56)	1				
F60	1022	T型取付台当てカラー	Collar	1				
F61	MS55	止めネジ	Screw (for Fig.60)	1				
F62	1023	T型当て板	Supporting plate	1				
F63	SM03	丸皿ネジ	Screw (for Fig.62)	2				
F64	1028	小押え (左・右) 10%ゲージ用	Small presser plate(left-right)10%gauge	1				
"	1028-1	" ( " ) 12% "	" " 12% "	1				
"	1028-2	" ( " ) 8% "	" " 8% "	1				
"	1028-3	" ( " ) 14% "	" " 14% "	1				
"	1028-4	" ( " ) 16% "	" " 16% "	1				
"	1028-5	" ( " ) 18% "	" " 18% "	1				
"	1028-6	" ( " ) 20% "	" " 20% "	1				
F65	1027	小押え止めピン	Set pin	1				
F66	M320	止めネジ	Screw (for Fig.65)	1				
F67	M315	小押え調整ネジ	Adjusting screw	4				
F68	N003	ナット	Nut	4				
F69	1029	小押えバネ	Spring	1				
F70	1026	小押え取付台	Set base	1				
F71	M410	止めネジ	Cap screw	2				
F72	SW04	スプリングワッシャー	Spring washer	2				
F73	W004	ワッシャー	Washer	2				
FS01	KS001	小押えセット	Small presser set	1				
F74	1018R	T型定規(両玉) 10%ゲージ用	Doubl-welf patch guide 10%gauge					
"	1018K	" (片玉) "	Single-welf patch guide 10%gauge L-type					
"	1018H	" (変形片玉) "	Offset-welf patch guide 10%gauge					
"	1018M	" (ダブル片玉) "	Single-welf patch guide 10%gauge T-type					
"	1018R1	" (両玉) 12%ゲージ用	Doubl-welf patch guide 12%gauge					
"	1018K1	" (片玉) "	Single-welf patch guide 12%gauge L-type					
"	1018H1	" (変形片玉) "	Offset-welf patch guide 12%gauge					
"	1018M1	" (ダブル片玉) "	Single-welf patch guide 12%gauge T-type					
"	1018R2	" (両玉) 8%ゲージ用	Doubl-welf patch guide 8%gauge					
"	1018K2	" (片玉) "	Single-welf patch guide 8%gauge L-type					
"	1018H2	" (変形片玉) "	Offset-welf patch guide 8%gauge					
"	1018M2	" (ダブル片玉) "	Single-welf patch guide 8%gauge T-type					
"	1018R3	" (両玉) 14%ゲージ用	Doubl-welf patch guide 14%gauge					
"	1018K3	" (片玉) "	Single-welf patch guide 14%gauge L-type					
"	1018H3	" (変形片玉) "	Offset-welf patch guide 14%gauge					
"	1018M3	" (ダブル片玉) "	Single-welf patch guide 14%gauge T-type					
"	1018R4	" (両玉) 16%ゲージ用	Doubl-welf patch guide 16%gauge					
"	1018K4	" (片玉) "	Single-welf patch guide 16%gauge L-type					
"	1018H4	" (変形片玉) "	Offset-welf patch guide 16%gauge					
"	1018M4	" (ダブル片玉) "	Single-welf patch guide 16%gauge T-type					
"	1018R5	" (両玉) 18%ゲージ用	Doubl-welf patch guide 18%gauge					
"	1018K5	" (片玉) "	Single-welf patch guide 18%gauge L-type					
"	1018H5	" (変形片玉) "	Offset-welf patch guide 18%gauge					
"	1018M5	" (ダブル片玉) "	Single-welf patch guide 18%gauge T-type					
"	1018R6	" (両玉) 20%ゲージ用	Doubl-welf patch guide 20%gauge					
"	1018K6	" (片玉) "	Single-welf patch guide 20%gauge L-type					
"	1018H6	" (変形片玉) "	Offset-welf patch guide 20%gauge					
"	1018M6	" (ダブル片玉) "	Single-welf patch guide 20%gauge T-type					
F75	M510	止めネジ	Screw (for Fig.74)	2				
F76	SW05	スプリングワッシャー	Spring washer	2				

Fig. No.	部品番号 Parts. No.	部 品 名	Description	個・台 Amt. Req.	共通部品 Common Parts			
F77	W005	ワッシャー	Washer	2				
F78	1013	上糸ユルメ	Upper thread releaser	1				
F79	N003	ナット	Nut	2				
F80	1012	上糸ユルメシリンダー土台	Cylinder set base	1				
F81	M410	止めネジ	Screw (for Fig.80)	2				
F82	SW04	スプリングワッシャー	Spring washer	2				
F83	W004	ワッシャー	Washer	2				
F84	1014	上糸ユルメシリンダー先端金具	Cylinder rod supporting bracket	1				
F85	1015	先端金具土台	Base	1				
F86	1014-1	先端金具当て板	Supporting plate	1				
F87	M420	止めネジ	Screw (for Fig.85)	2				
F88	1016	マーキングランプ止板(フラップ用)	Marking lamp set plate(with flap)	1				
"	1017	" (フラップなし用)	" (with out flap)	1				
F89	M615	止めネジ	Screw (for marking lamp set plate)	2				
F90	SW06	スプリングワッシャー	Spring washer	2				
F91	W056	ワッシャー	Washer	2				
F92	B630	マーキングランプ止めネジ	Screw (for marking lamp)	4				
F93	W0B6	ワッシャー	Washer	4				
F94	NK06	ナット	Nut	4				
F95	2056L	光電管取付板 (左)	Photocell set plate (left)	1				
F96	2056R	" (右)	" (right)	1				
F97	M510	止めネジ	Screw (for Fig.95,96)	2				
F98	M322	光電管止めネジ	Screw (for photocell)	3				
F99	M325	"	" ( " )	1				
F100	SW03	スプリングワッシャー	Spring washer	4				
F101	W003	ワッシャー	Washer	4				
F102	N003	ナット	Nut	4				
F103	2057L	光電管取付板土台 (左)	Set base (left)	1				
F104	M515	止めネジ	Screw (for Fig.103)	2				
F105	SW05	スプリングワッシャー	Spring washer	2				
F106	W005	ワッシャー	Washer	2				
F107	2057R	光電管取付板土台 (右)	Set base (right)	1				
F108	SM04	丸平ネジ	Screw (for Fig.107)	2				
F109	2058L	光電管取付板止めピンネジ (左)	Pin screw (left)	1				
F110	2058R	" (右)	" (right)	1				
F111	SMN38	ナット	Nut	2				



頭 部 関 係 [T]  
Head

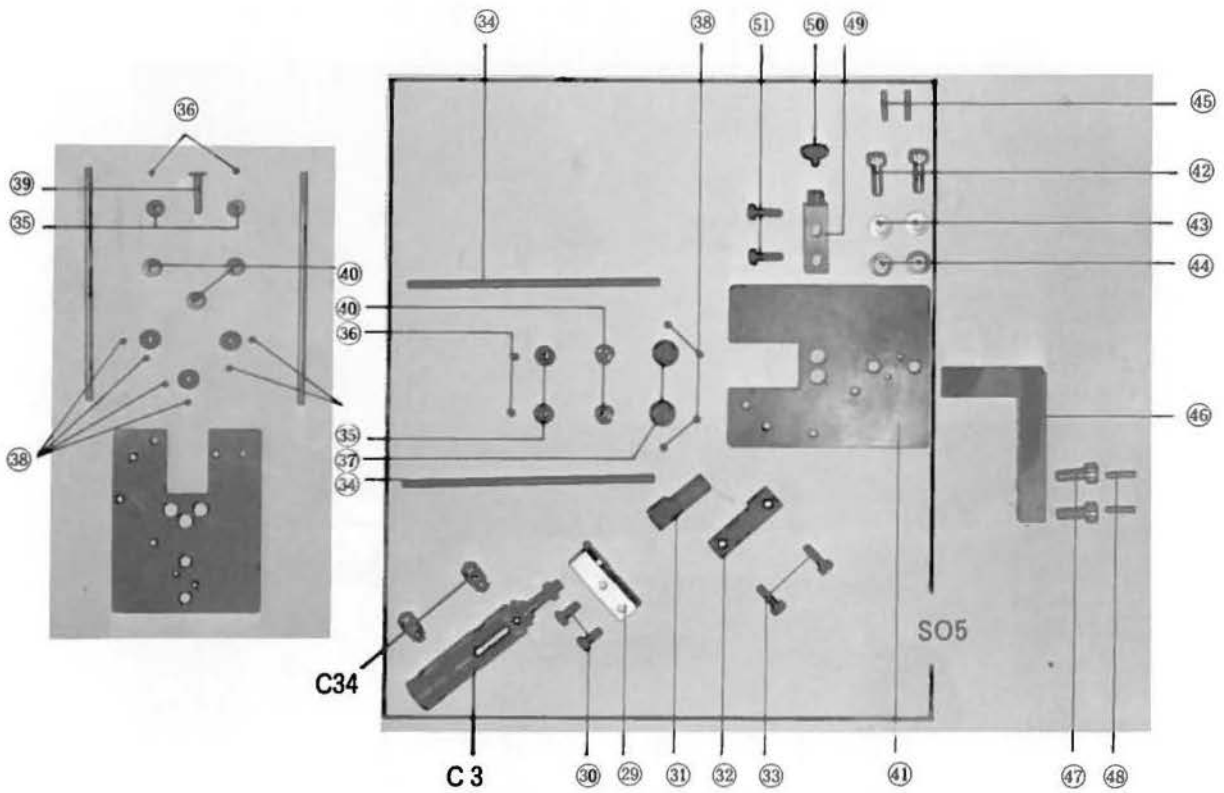
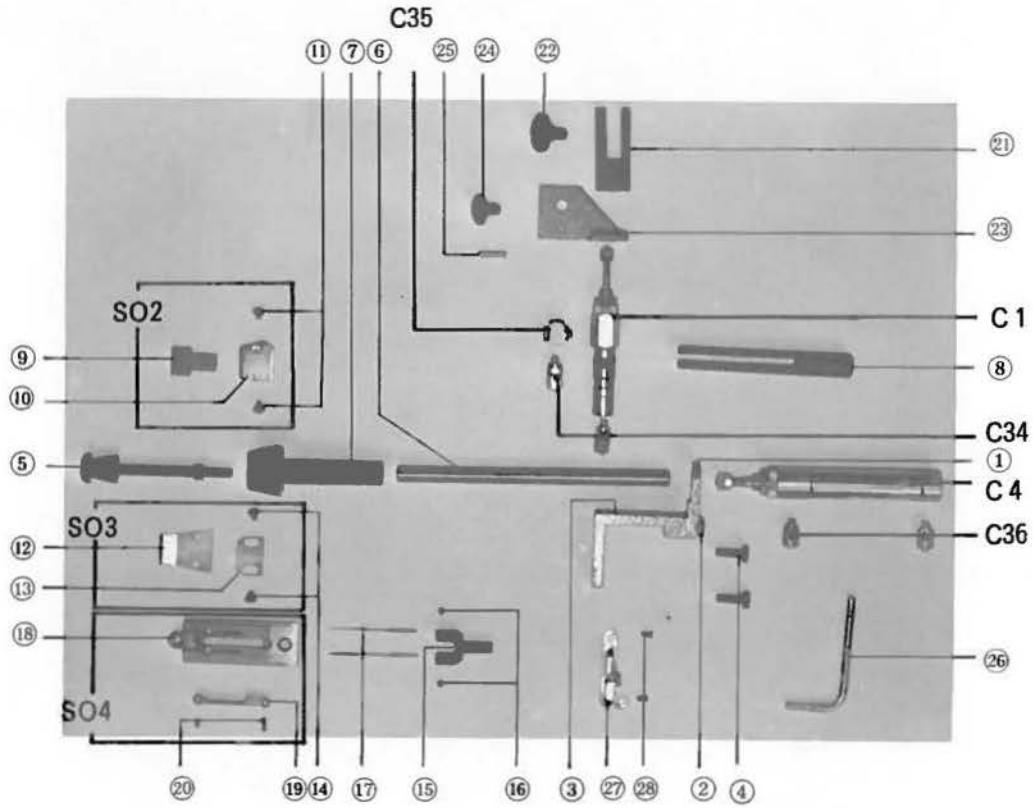

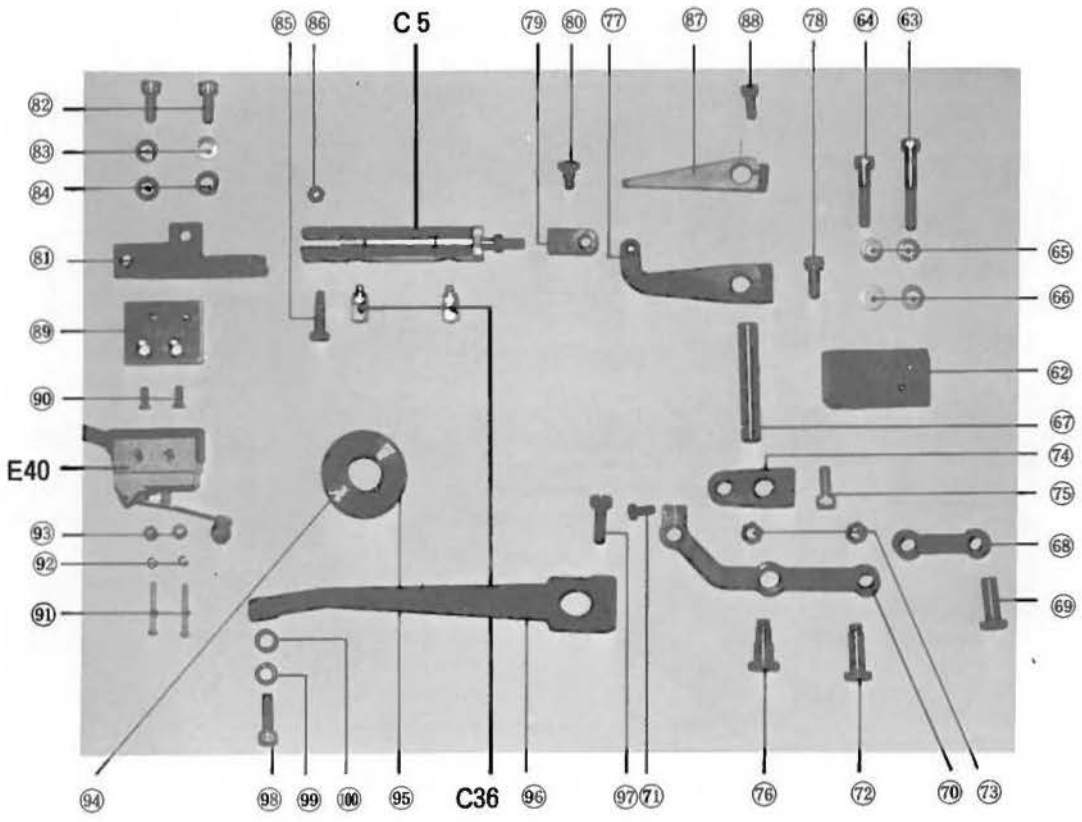
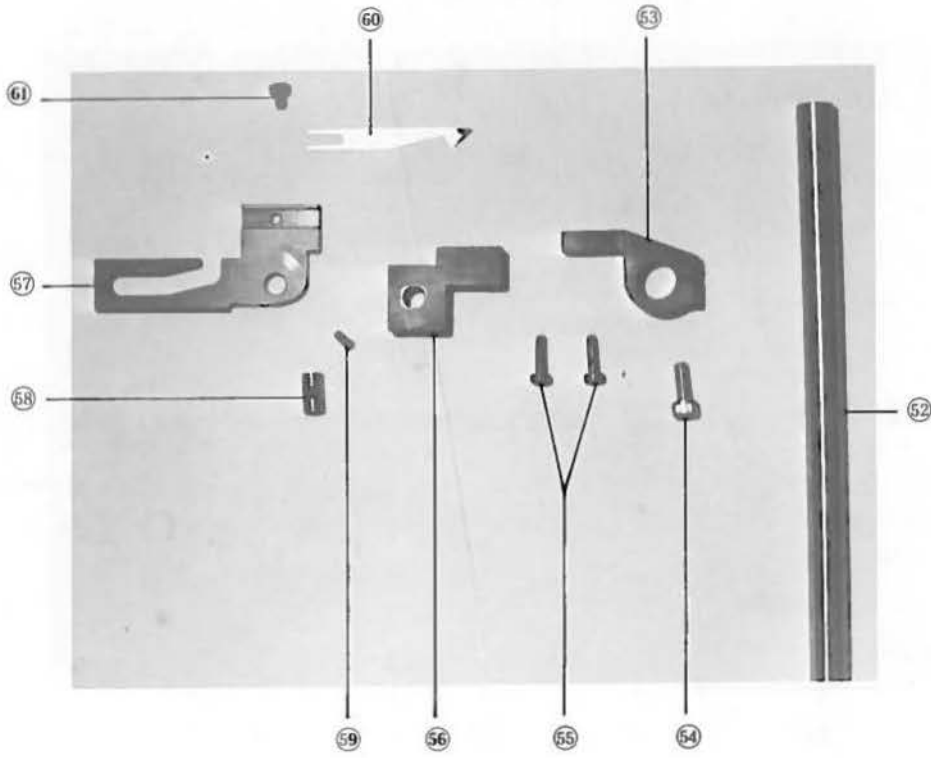

Fig. No.	部品番号 Parts. No.	部 品 名	Description	個・台 Amt. Req.	共通部品 Common Parts			
T 1	2002	上糸引っ掛けシリンダー取付板	Cylinder set plate	1				
T 2	SM04	丸平ネジ	Screw (for Fig.1)	2				
T 3	2001	上糸引っ掛けシリンダー取付板土台	Base	1				
T 4	SM04	丸平ネジ	Screw (for Fig.3)	2				
T 5	2004	上糸引っ掛け (8%~12%ゲージ用)	Upper thread holder(8%~12%gauge)	1				
"	2004-1	" (14%~16%ゲージ用)	" (14%~16% " )	1				
"	2004-3	" (18%~20%ゲージ用)	" (18%~20% " )	1				
T 6	2003	上糸引っ掛け棒	Upper thread holder bar	1				
T 7	2005	上糸引っ掛け土台	Upper thread holder base	1				
T 8	2050	上糸引っ掛け案内金	Upper thread holder positioning guide	1				
T 9	2007	上糸切刃 (8%~12%ゲージ用)	Upper thread knife(8%~12%gauge)	1				
"	2007-1	" (14%~16%ゲージ用)	" (14%,16% " )	1				
"	2007-2	" (18%~20%ゲージ用)	" (18%,20% " )	1				
T 10	2006	上糸切刃押え板	Support plate	1				
T 11	SM18	丸平ネジ	Screw (for Fig.10)	2				
TS02	US002	上糸切刃セット	Upper thrad knife set	1				
T 12	2008	上糸掴みバネ (8%~12%ゲージ用)	Upper thread holding spring(8%~12%gauge)	1				
"	2008-1	" (14%~16%ゲージ用)	" (14%,16% " )	1				
"	2008-2	" (18%~20%ゲージ用)	" (18%,20% " )	1				
T 13	2008-H	上糸掴みバネ補助バネ	Support spring	1				
T 14	SM05	丸平ネジ	Screw (for Fig.12)	2				
TS03	US001	上糸掴みバネセット	Upper thread holding spring set	1				
T 15	2015	針株 10%ゲージ用	Needle clamp 10%gauge	1				
"	2015-1	" 12%ゲージ用	" 12%gauge	1				
"	2015-2	" 8%ゲージ用	" 8%gauge	1				
"	2015-3	" 14%ゲージ用	" 14%gauge	1				
"	2015-4	" 16%ゲージ用	" 16%gauge	1				
"	2015-5	" 18%ゲージ用	" 18%gauge	1				
"	2015-6	" 20%ゲージ用	" 20%gauge	1				
T 16	SM06	針止めネジ	Needle set screw	2				
T 17	NE16	針	Needle	2				
T 18	2013	針板 10%ゲージ用	Needle plate 10%gauge	1				
"	2013-1	" 12%ゲージ用	" 12%gauge	1				
"	2013-2	" 8%ゲージ用	" 8%gauge	1				
"	2013-3	" 14%ゲージ用	" 14%gauge	1				
"	2013-4	" 16%ゲージ用	" 16%gauge	1				
"	2013-5	" 18%ゲージ用	" 18%gauge	1				
"	2013-6	" 20%ゲージ用	" 20%gauge	1				
T 19	2053	針板メス	Lower knife	1				
T 20	M305S	丸皿ネジ	Screw (for Fig.19)	1				
"	M310S	"	" ( " )	1				
TS04	HS001	針板セット	Needle plate set	1				
T 21	2009	上糸調節器緩め	Thread tension regulator releaser	1				
T 22	2010	段付平ネジ	Screw (for Fig.21)	1				
T 23	2011	上糸緩めシリンダー取付板	Cylinder set plate	1				
T 24	SM07	丸平ネジ	Screw (for Fig.23)	1				
T 25	P310	ノックピン	Nock pin	1				
T 26	2059	糸案内 (トップカバー)	Thread guide (top cover)	1				
T 27	2062	" (アーム 上)	" (upper)	1				
T 28	SM08	丸皿ネジ	Screw (for Fig.27)	2				
T 29	2016	下糸切シリンダー取付板	Cylinder set plate	1				
T 30	SM09	丸平ネジ	Screw (for Fig.29)	2				
T 31	2017	ラックギヤ (8%,10%,14%~20%ゲージ用)	Rack gear(8%,10%,14%~20%gauge)	1				
"	2017-1	" (12%ゲージ用)	" (12%gauge)	1				
T 32	2018	ラックギヤ スライド土台	Slide base	1				

Fig. No.	部品番号 Parts. No.	部 品 名	Description	個・台 Amt. Req.	共通部品 Common Parts			
T33	SM11	丸平ネジ	Screw (for Fig.32)	2				
T34	2020	下糸切棒	Lower thread trimmer ber	2				
T35	2021	下糸切棒カラー(8%~12%ゲージ用)	Collar (8%~12%gauge)	2				
"	"	" (14%~20%ゲージ用)	" (14%~20%gauge)	2				
T36	SM10	頭なしネジ	Screw (for Fig.35)	2				
T37	2019	下糸切棒ギヤ(8%,10%ゲージ用)	Giar (8%,10%gauge)	2				
"	2019-1	" (12%ゲージ用)	" (12%gauge)	2				
"	2019	" (14%~20%ゲージ用)	" (14%~20%gauge)	3				
T38	SM10	頭なしネジ(8%~12%ゲージ用)	Screw (8%~12%gauge)	4				
"	"	" (14%~20%ゲージ用)	" (14%~20%gauge)	6				
T39		中間ギヤ用ピン(14%~20%ゲージ用)	Center gear set pin(14%~20%gauge)	1				
T40	2022-M	下糸切ベース板用メタル(8%~12%ゲージ用)	Bushing (8%~12%gauge)	2				
"	"	" (14%~20%ゲージ用)	" (14%~20%gauge)	3				
T41	2022	下糸切ベース板(10%ゲージ用)	Lower thread trimmer base plate(10%gauge)	1				
"	2022-1	" (12% " )	" (12% " )	1				
"	2022-2	" (8% " )	" (8% " )	1				
"	2022-3	" (14% " )	" (14% " )	1				
"	2022-4	" (16% " )	" (16% " )	1				
"	2022-5	" (18% " )	" (18% " )	1				
"	2022-6	" (20% " )	" (20% " )	1				
T42	M615	止めネジ	Screw (for Fig.41)	2				
T43	SW06	スプリングワッシャー	Spring washer	2				
T44	WOS6	ワッシャー	Washer	2				
T45	P315	ノックピン	Nock pin	2				
T46	2023	下糸切ベース板取付土台	Set base	1				
T47	M615	止めネジ	Screw (for Fig.46)	2				
T48	P315	ノックピン	Nock pin	2				
T49	2029	センターメス案内軸	Center knife guide	1				
T50	SM02	丸平ネジ	Screw	1				
T51	SM20	丸平ネジ	Screw (for Fig.49)	2				
TS05	US003	下糸切セット	Lower thread trimmer set	1				
T52	2024	センターメス作動シャフト	Center knife operating shaft	1				
T53	2025	センターメス作動第1腕	Center knife operating arm #1	1				
T54	M615	止めネジ	Screw (for Fig.53)	1				
T55	SM11	丸平ネジ	Set screw (for Fig.56)	2				
T56	2026	センターメス作動第2腕(左)	Center knife operating arm #2 (left)	1				
T57	2027	センターメス取付土台	Center knife set base	1				
T58	2028	ピン	Pin	1				
T59	SM12	丸平ネジ	Screw (for Fig.58)	1				
T60	2030	センターメス	Center knife	1				
T61	SM13	丸平ネジ	Screw (for Fig.60)	1				
T62	2035	センターメスリンク取付ブロック	Set base	1				
T63	M640	止めネジ	Screw (for Fig.62)	1				
T64	M630	止めネジ	" ( " )	1				
T65	SW06	スプリングワッシャー	Spring washer	2				
T66	WOS6	ワッシャー	Washer	2				
T67	2037	センターメスリンク取付ブロックシャフト	Shaft	1				
T68	2039	センターメス作動第2リンク	Center knife operating link #2	1				
T69	2042	ピン	Pin	1				
T70	2038	センターメス作動第1リンク	Center knife operating link #1	1				
T71	SM09	丸平ネジ	Screw	1				
T72	2040	段付ネジ	Screw	1				
T73	N932	ナット	Nut	1				
T74	2036	センターメス作動第2腕(右)	Center knife operating arm #2 (right)	1				
T75	M615	止めネジ	Screw	1				

Fig. No.	部品番号 Parts. No.	部品名	Description	個・台 Amt. Req.	共通部品 Common Parts			
T76	2041	段付ネジ	Screw	1				
T77	2034	センターメスシリンダー作動腕	Center knife operating arm	1				
T78	M615	止めネジ	Screw (for Fig.77)	1				
T79	2033	センターメスシリンダー先端金具	Supporting bracket	1				
T80	SM14	段付ネジ	Screw (for Fig.79)	1				
T81	2031	センターメスシリンダー止め金具	Cylinder set base	1				
T82	M615	止めネジ	Screw (for Fig.81)	2				
T83	SW06	スプリングワッシャー	Spring washer	2				
T84	W0S6	ワッシャー	Washer	2				
T85	2032	段付平ネジ	Screw (for cylinder)	1				
T86	N1164	ナット	Nut	1				
T87	2055	センターメス安全スイッチ当て板	Switch activation plate	1				
T88	M515	止めネジ	Screw (for Fig.87)	1				
T89	2051	センターメス安全スイッチ止め板	Set plate	1				
T90	SM15	丸皿ネジ	Screw (for Fig.89)	2				
T91	M325	センターメス安全スイッチ止めネジ	Screw (for center knife safety switch)	2				
T92	SW03	スプリングワッシャー	Spring washer	2				
T93	W003	ワッシャー	Washer	2				
T94	2043	センターメス作動調節器止めカラー	Center knife regulator set collar	1				
T95	SM16	丸平ネジ	Screw	2				
T96	2045	針棒揺動軸止め金具	Needle bar rock shaft stoper	1				
T97	SM17	丸平ネジ	Screw (for Fig.95)	1				
T98	M620	止めネジ	Screw (for Fig.95)	1				
T99	SW06	スプリングワッシャー	Spring washer	1				
T100	W0S6	ワッシャー	Washer	1				

# 大押え機構

## Main clamp mechanism

[M]

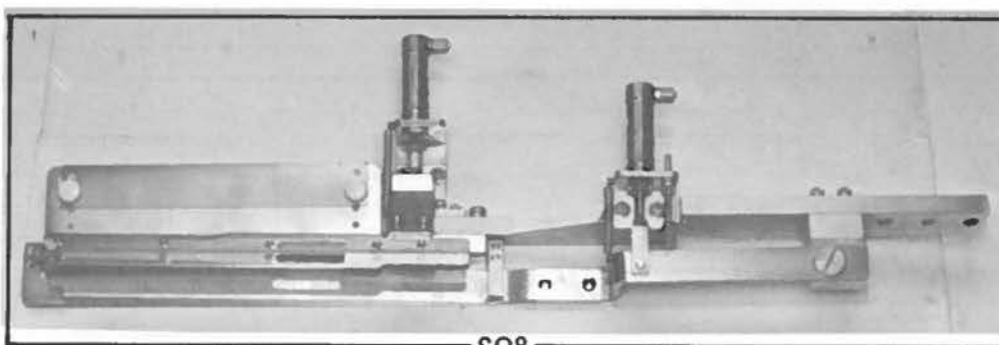
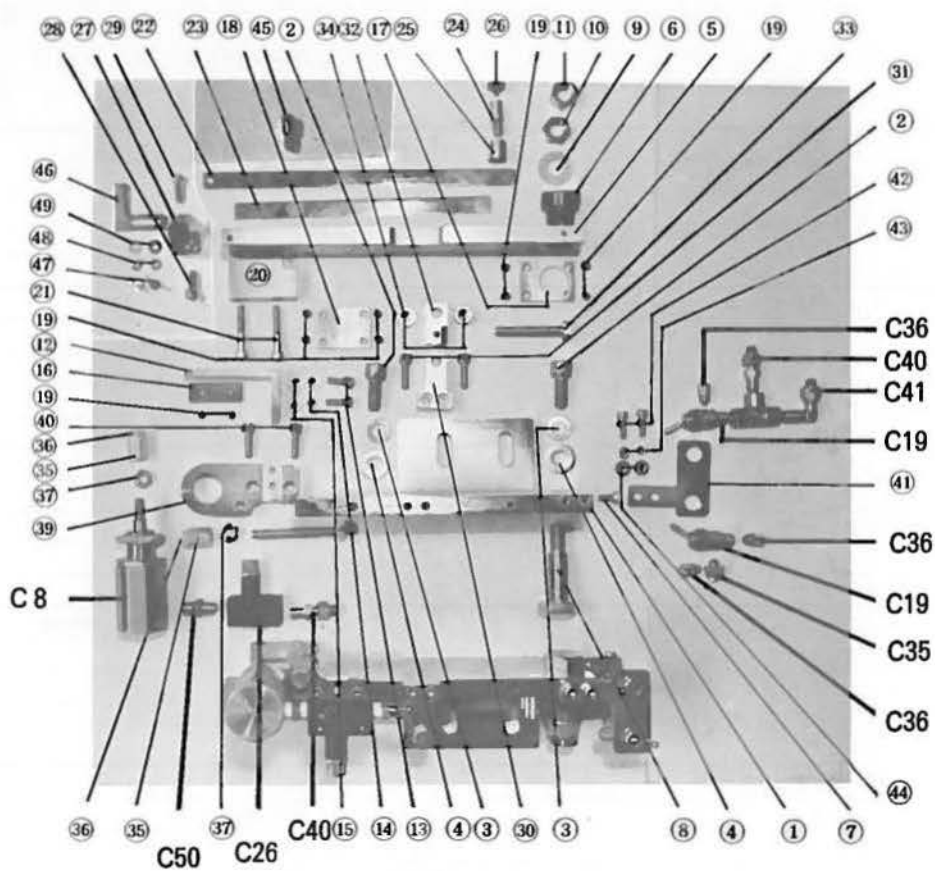

S08

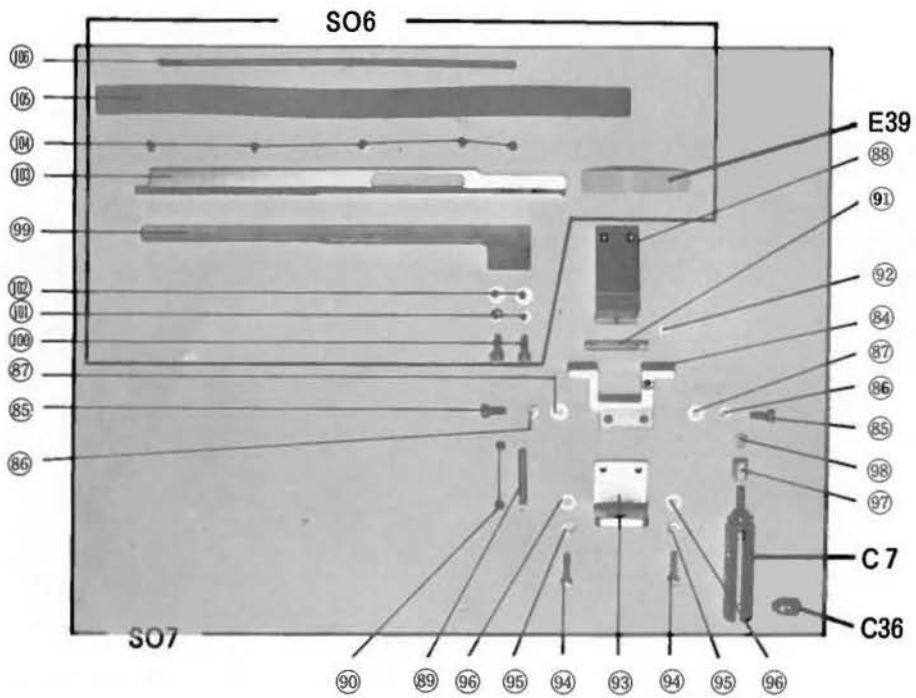
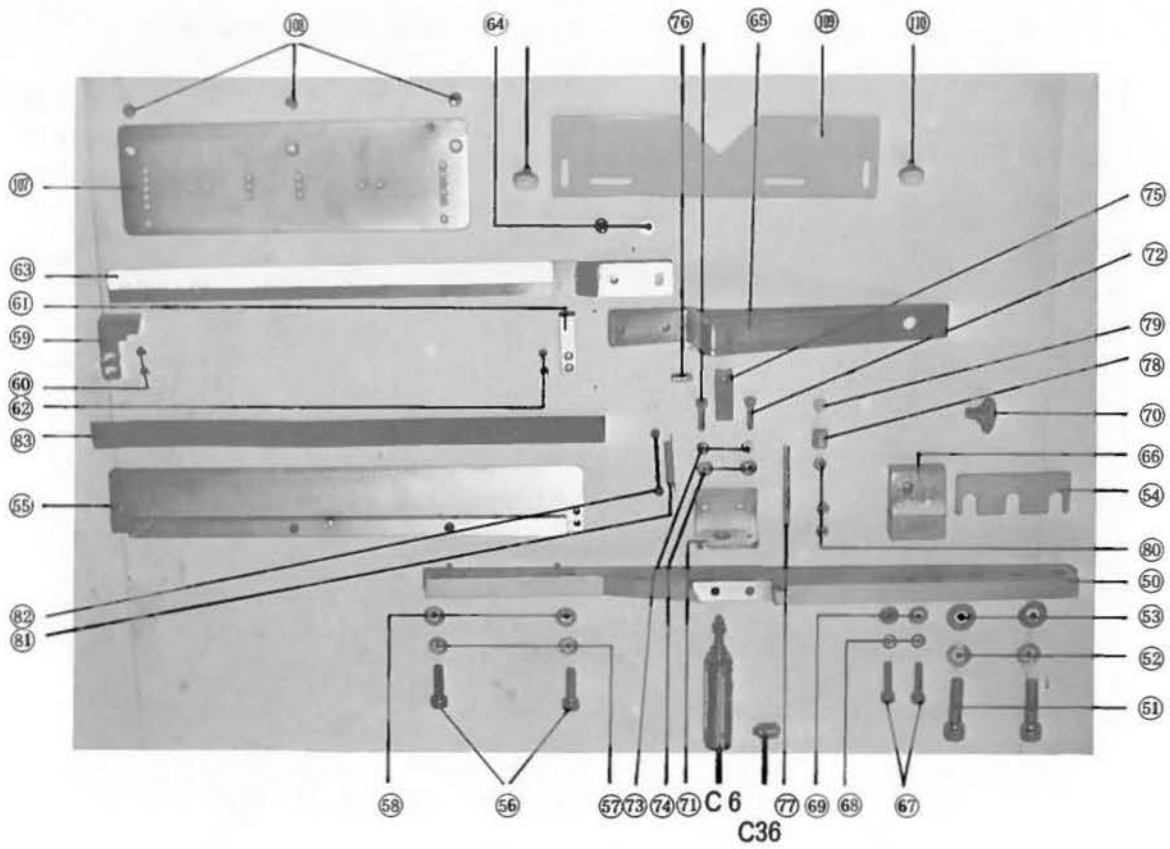

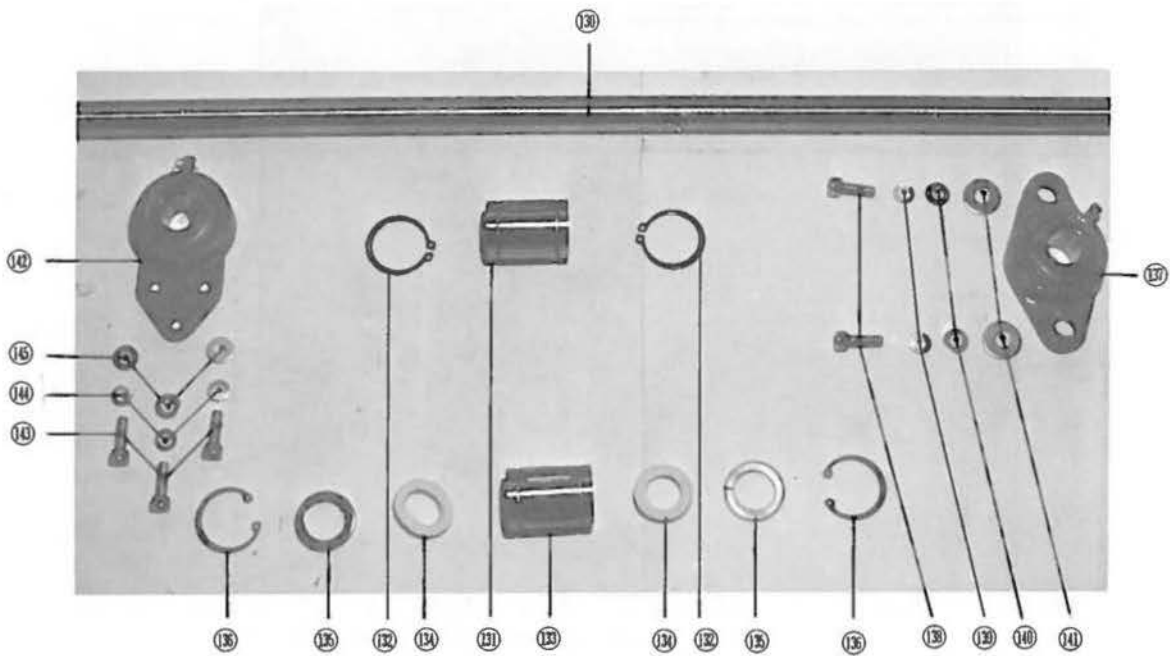
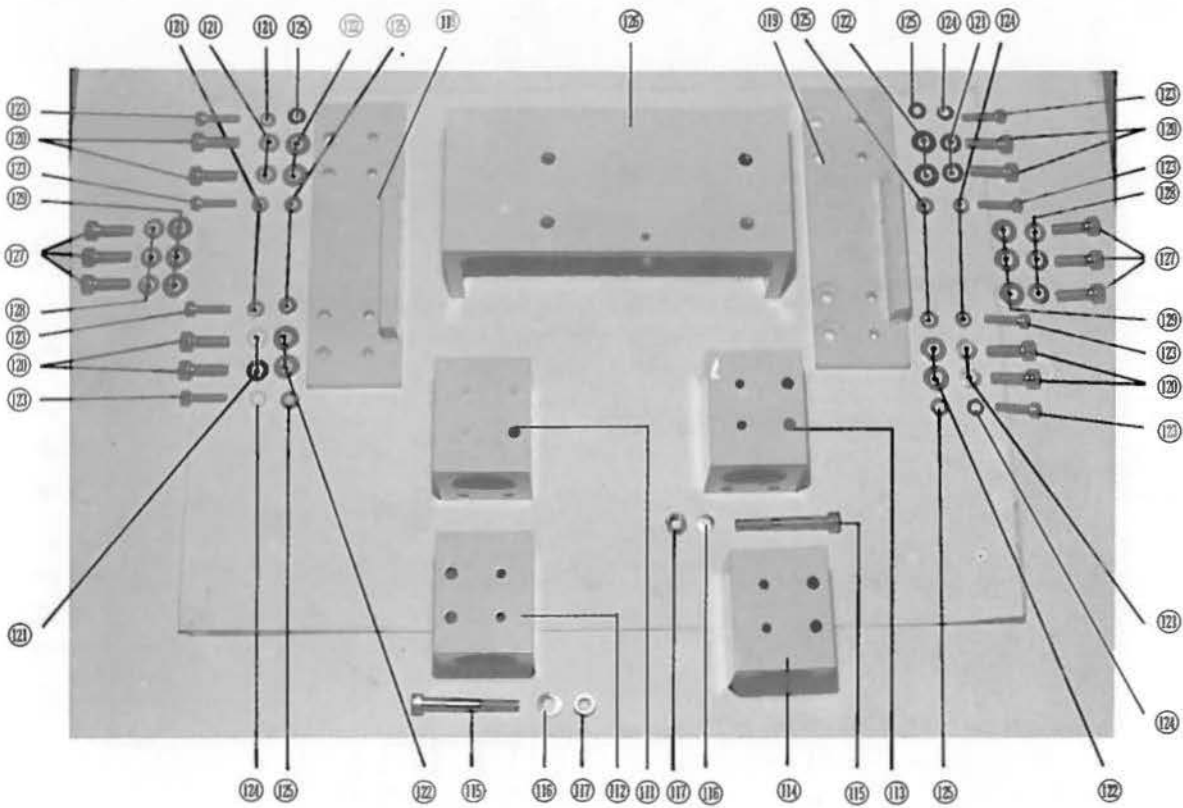



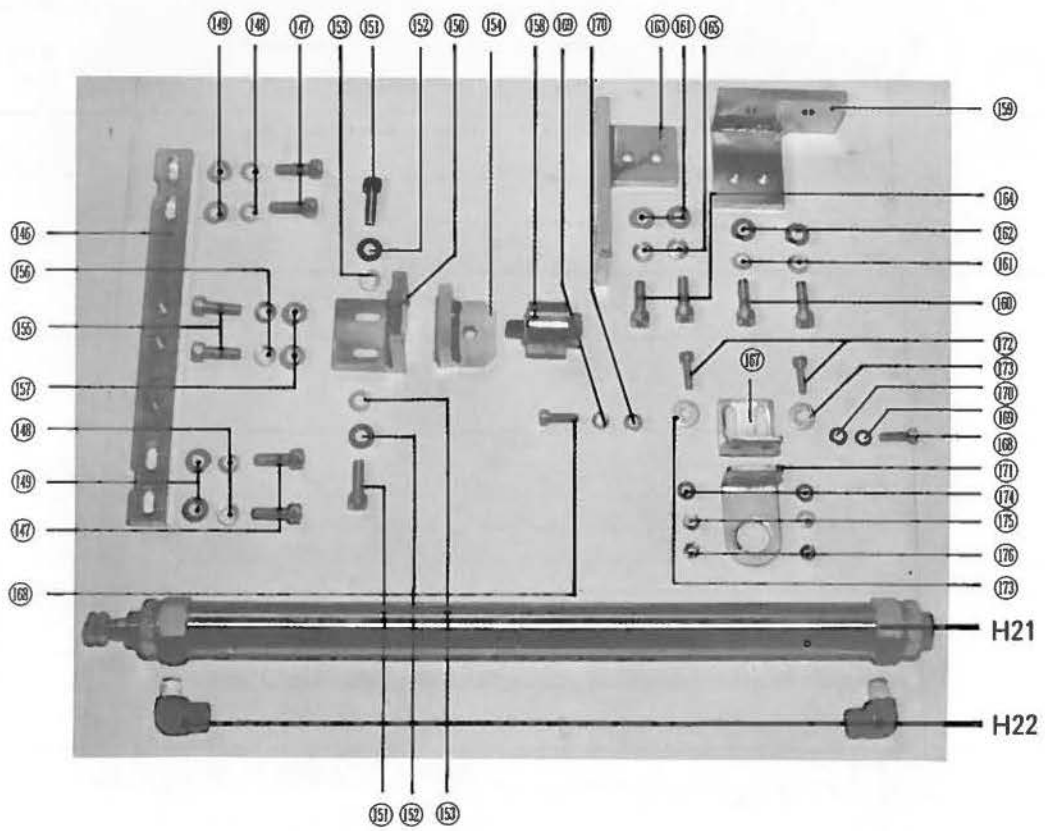

Fig. No.	部品番号 Parts. No.	部 品 名	Description	個・台 Amt. Req.	共通部品 Common Parts			
M 1	3001L	大押え腕取付ベース (左)	Main clamp set base (left)	1				
"	3001R	" (右)	" (right)	1				
M 2	M1025	止めネジ	Screw (for Fig.1)	4				
M 3	SW10	スプリングワッシャー	Spring washer	4				
M 4	WOB10	ワッシャー	Washer	4				
M 5	3002L	大押え第1腕 (左)	Main clamp arm #1 (left)	1				
"	3002R	" (右)	" (right)	1				
M 6	3003	メタル	Bushing	2				
M 7	M510	止めネジ	Screw (for Fig.6)	2				
M 8	3005	段付平ネジ	Pin screw	2				
M 9	3005-1	ワッシャー	Washer	2				
M10	N012	ナット	Nut	2				
M11	NJ12	ナット	"	2				
M12	3006	大押え第1腕振れ止め金具	Vibration stopper plate	2				
M13	M515	止めネジ	Screw (for Fig.12)	4				
M14	SW05	スプリングワッシャー	Spring washer	4				
M15	W005	ワッシャー	Washer	4				
M16	3007	大押え第1腕振れ止めスラスト板	Thrust plate (for Fig.12)	2				
M17	3004	大押え第1腕スラスト板 (後)	" (for Fig.5) rear	2				
M18	3004-1	" (前)	" ( " ) forward	2				
M19	IN18	止めネジ	Screw (for Fig.16,17,18)	20				
M20	3008	大押えシリンダー押し当て板	Plate	2				
M21	M635	止めネジ	Screw (for Fig.20)	4				
M22	3009	大押え腕板バネ	Spring	2				
M23	3009-1	大押え腕補助板バネ	Support spring	2				
M24	3010	大押え腕板バネ用ピンネジ	Pin screw	2				
M25	3010-1	" ローラー	Roller	2				
M26	SM02	丸平ネジ	Screw (for Fig.24)	2				
M27	3012L	大押え腕板バネ止め金具 (左)	Set block (left)	1				
"	3012R	" (右)	" (right)	1				
M28	M510	止めネジ	Screw (for Fig.27)	2				
M29	M415	板バネ止めネジ	Screw (for Fig.22)	2				
M30	3015	大押えバネ調整ネジ土台	Base	2				
M31	M615	止めネジ	Screw (for Fig.30)	4				
M32	3016	大押えバネ調整金具	Regulatar base	2				
M33	B850	ネジ	Screw	2				
M34	N008	ナット	Nut	4				
M35	3013	大押えシリンダー先端金具	Cylinder supporting bracket	4				
M36	3013-1	" テフロン	" teflon	4				
M37	N008	ナット	Nut	4				
M38	B860	大押え高さ調節ネジ	Regulatar screw	2				
M39	3017L	大押えシリンダー取付板 (左)	Cylinder set plate (left)	1				
"	3017R	" (右)	" (right)	1				
M40	M615	止めネジ	Screw	4				
M41	3018	エアーストップバルブ取付板	Toggle switch set plate	2				
M42	M515	止めネジ	Set screw	4				
M43	SW04	スプリングワッシャー	Spring washer	4				
M44	W004	ワッシャー	Washer	4				
M45	3049	大押え第2腕止めピンネジ	Pin screw	2				
M46	3051	大押え第2腕取付当て板	Receive plate	2				
M47	SM18	止めネジ	Screw	4				
M48	SW04	スプリングワッシャー	Spring washer	4				
M49	W004	ワッシャー	Washer	4				
M50	3019L	大押え第2腕 (左) フラップ用	Main clamp arm #2 (left) with flap	1				
"	3019R	" (右) "	" (right) "	1				

Fig. No.	部品番号 Parts. No.	部 品 名	Description	個・台 Amt. Req.	共通部品 Common Parts			
M50	3019L1	大押え第2腕(左)フラップなし	Main clamp arm #2(left)with out flap	1				
"	3019R1	"(右)"	"(right)"	1				
M51	M830	止めネジ	Set screw	4				
M52	SW08	スプリングワッシャー	Spring washer	4				
M53	W008	ワッシャー	Washer	4				
M54	3047	スペーサー 0.5%	Spacer 0.5%					
"	3047-1	" 2.5%	" 2.5%					
"	3047-2	" 3.5%	" 3.5%					
"	3047-3	" 4%	" 4%					
"	3047-4	" 5%	" 5%					
"	3047-5	" 6%	" 6%					
"	3047-6	" 7%	" 7%					
"	3047-7	" 8%	" 8%					
"	3047-8	" 9%	" 9%					
"	3047-9	" 10%	" 10%					
M55	3020L	大押え(左) フラップ	Main clamp(left)with flap					
"	3020R	"(右)"	"(right)"					
"	3020L1	"(左) フラップなし	"(left)with out flap	1				
"	3020R1	"(右)"	"(right)"	1				
"	3020L2	"(左)16%~20%ゲージ用	"(left)16%~20%gauge					
"	3020R2	"(右)"	"(right)"					
M56	M620	止めネジ	Screw (for Fig.55)	2				
M57	SW06	スプリングワッシャー	Spring washer	2				
M58	W006	ワッシャー	Washer	2				
M59	3027L	折り込み板ガイド前(左)フラップ用	Folder brade guide forward(left)with flap	1				
"	3027R	"(右)"	"(right)"	1				
"	3027L1	"(左)フラップなし	"(left)with out flap	1				
"	3027R1	"(右)"	"(right)"	1				
"	3027L2	"(左)(16%~20%)	"(left)(16%~20%)	1				
"	3027R2	"(右)ゲージフラップ用)	"(right)with flap /)	1				
"	3027L3	"(左)(16%~20%)	"(left)(16%~20%)	1				
"	3027R3	"(右)ゲージフラップなし用)	"(right)without flap/)	1				
M60	SM19	止めネジ	Screw (for Fig.59)	4				
M61	3026L	折り込み板ガイド後(左)	Folder brade guide rear(left)	1				
"	3026R	"(右)"	"(right)"	1				
"	3026L1	"(左)16%~20%ゲージ用	"(left)16%~20%gauge	1				
"	3026R1	"(右)"	"(right)"	1				
M62	SM03	止めネジ	Screw (for Fig.61)	4				
M63	3024L	折り込み板(左)フラップ用	Folder blade(left)with flap	1				
"	3024R	"(右)"	"(right)"	1				
"	3024L1	"(左)フラップなし用	"(left)with out flap	1				
"	3024R1	"(右)"	"(right)"	1				
"	3024L2	"(左)16%~20%ゲージ用	"(left)16%~20%gauge					
"	3024R2	"(右)"	"(right)"					
M64	SM21	止めネジ	Screw (for Fig.63)	4				
M65	3022L	折り込み板取付板(左)	Set plate (left)	1				
"	3022R	"(右)"	"(right)"	1				
M66	3021L	折り込み板土台(左)	Base (left)	1				
"	3021R	"(右)"	"(right)"	1				
M67	M625	止めネジ	Screw (for Fig.66)	4				
M68	SW06	スプリングワッシャー	Spring washer	4				
M69	W006	ワッシャー	Washer	4				
M70	3023	段付ネジ	Screw (for Fig.65)	2				
M71	3046L	折り込みシリンダー取付板(左)	Cylinder set plate (left)	1				
"	3046R	"(右)"	"(right)"	1				

Fig. No.	部品番号 Parts. No.	部 品 名	Description	個・台 Amt. Req.	共通部品 Common Parts			
M72	M415	止めネジ	Screw (for Fig.71)	4				
M73	SW04	スプリングワッシャー	Spring washer	4				
M74	W004	ワッシャー	Washer	4				
M75	3029	折り込みシリンダー先端金具	Cylinder supporting braket	2				
M76	3029-1	ピンネジ	Pin screw	2				
M77	3028	折り込み板調節ネジ	Adjusting screw	2				
M78	3028-1	" 先端金具	Supporting bracket	2				
M79	3031	" " テフロン	Teflon	2				
M80	N004	ナット	Nut	6				
M81	3050	折り込み板引バネ	Spring	2				
M82	SM22	止めネジ	Screw (for Fig.81)	4				
M83	3048	大押え裏ゴム 2%	Rubber 2%					
"	3048-1	" 3%	" 3%					
"	3048-2	" 4%	" 4%					
"	3048-3	" 5%	" 5%					
M84	3032L	フラップ押え取付台 (左)	Flap clamp set base (left)	1				
"	3032R	" (右)	" (right)	1				
M85	M415	止めネジ	Screw (for Fig.84)	4				
M86	SW04	スプリングワッシャー	Spring washer	4				
M87	W004	ワッシャー	Washer	4				
M88	3033L	フラップ押え台 (左)	Flap clamp base (left)	1				
"	3033R	" (右)	" (right)	1				
M89	3050-1	フラップ押え引バネ	Spring	2				
M90	SM22	止めネジ	Screw (for Fig.89)	4				
M91	3034	ピン	Pin	2				
M92	SM19	止めネジ	Screw (for Fig.91)	2				
M93	3035L	フラップ押えシリンダー取付板 (左)	Cylinder set plate (left)	1				
"	3035R	" (右)	" (right)	1				
M94	M410	止めネジ	Screw (for Fig.93)	4				
M95	SW04	スプリングワッシャー	Spring washer	4				
M96	W004	ワッシャー	Washer	4				
M97	3030A	フラップシリンダー先端金具	Cylinder supporting braket	2				
M98	3031	" テフロン	Teflon	2				
M99	3037L	フラップ押え取付板 (左)	Flap clamp set plate (left)	1				
"	3037R	" (右)	" (right)	1				
M100	M410	止めネジ	Screw (for Fig.97)	4				
M101	SW04	スプリングワッシャー	Spring washer	4				
M102	W004	ワッシャー	Washer	4				
M103	3036L	フラップ押え板 (左) 10%ゲージ用	Flap clamp plate 10%gauge(left)	1				
"	3036R	" (右) "	" " (right)	1				
"	3036L1	" (左) 12%ゲージ用	" 12%gauge(left)					
"	3036R1	" (右) "	" " (right)					
"	3036L2	" (左) 8%ゲージ用	" 8%gauge(left)					
"	3036R2	" (右) "	" " (right)					
"	3036L3	" (左) 14%ゲージ用	" 14%gauge(left)					
"	3036R3	" (右) "	" " (right)					
"	3036L4	" (左) 16%ゲージ用	" 16%gauge(left)					
"	3036R4	" (右) "	" " (right)					
"	3036L5	" (左) 18%ゲージ用	" 18%gauge(left)					
"	3036R5	" (右) "	" " (right)					
"	3036L6	" (左) 20%ゲージ用	" 20%gauge(left)					
"	3036R6	" (右) "	" " (right)					
M104	SM19	止めネジ	Screw (for Fig.101)	10				
M105	3048	フラップ押え裏ゴム 2%	Rubber 2%	2				
M106	3048F	フラップ押え裏ゴム先端	" 1%	2				

Fig. No.	部品番号 Parts. No.	部 品 名	Description	個・台 Amt. Req.	共通部品 Common Parts			
S06	FS001L	フラップ押え板セット (左)	Flap clamp plate set (left)	1				
"	FS001R	" (右)	" (right)	1				
S07	FS002L	フラップ押えセット (左)	Flap clamp set (left)	1				
"	FS002R	" (右)	" (right)	1				
M107	3038	大押え上板 (左) フラップ用	Main clamp upper plate(left)with flap	1				
"	3038-1	" (右) "	" (right) "	1				
"	3038-2	" (左) フラップなし用	" (left)with out flap	1				
"	3038-4	" (右) "	" (right) "	1				
"	3038-5	" 16%~20%ゲージ用(左)	" (left)16%~20%gauge	1				
"	3038-6	" " (右)	" (right) "	1				
M108	SM15	丸皿ネジ	Screw (for Fig. 107)	6				
M109	3045	玉フラップアテ板	Patch,Flap,matelial seting plate	1				
"	3045-1	玉フラップ三角当て板	Patch,Flap,Tab matelial seting plate	1				
"	3045-2	スラックスフラップ当て板	Special flap matelial seting plate	1				
M110	M410-B	止めネジ	Screw (for Fig.107)	4				
S08	OS001L	大押えセット (左) フラップ用	Main clamp set(left)with flap	1				
"	OS001R	" (右) "	" (right) "	1				
"	OS002L	" (左) フラップなし用	" (left)with out flap	1				
"	OS002R	" (右) "	" (right) "	1				
"	OS003L	大押えセット(左)フラップ付用16%~20%ゲージ用	" (left)16%~20%gauge	1				
"	OS003R	" (右) " "	" (right) "	1				
"	OS004L	" (左) フラップなし用 "	" (left) "	1				
"	OS004R	" (右) " "	" (right) "	1				
M111	5060	大押え駆動ベースベアリングケース A	Main clamp operating base bearing case A	1				
M112	5061	" B	" B	1				
M113	5062	" C	" C	1				
M114	5063	" D	" D	1				
M115	M855	止めネジ	Screw	2				
M116	W008	ワッシャー	Washer	2				
M117	N008	ナット	Nut	2				
M118	5064	大押え駆動ベースベアリングケース取付台A	Set base A	1				
M119	5064-1	" B	Set base B	1				
M120	M820	止めネジ	Screw (for Fig. 118,119)	8				
M121	SW08	スプリングワッシャー	Spring washer	8				
M122	W008	ワッシャー	Washer	8				
M123	M620	止めネジ	Screw (for Fig. 118,119)	8				
M124	SW06	スプリングワッシャー	Spring washer	8				
M125	W006	ワッシャー	Washer	8				
M126	5065	大押え駆動ベース	Main clamp operating base	1				
M127	M820	止めネジ	Screw (for Fig. 126)	6				
M128	SW08	スプリングワッシャー	Spring washer	6				
M129	W008	ワッシャー	Washer	6				
M130	5096	大押え駆動シャフト	Main clamp operating shaft	2				
M131	5098	大押え駆動ベースベアリングA,D用	Bearing case (for Fig. 111,114)	2				
M132	5098-1	スナップリング	Snap ring	4				
M133	5097	大押え駆動ベースベアリングB,C用	Bearing case (for Fig. 112,113)	2				
M134	5099	フェルト	Felt	4				
M135	5099-1	フェルト止め	Felt stoper ring	4				
M136	5097-1	スナップリング	Snap ring	4				
M137	5100	大押え駆動シャフト取付台 (A)	Main clamp operating shaft base(A)	2				
M138	M830	止めネジ	Screw (for Fig. 137)	4				
M139	SW08	スプリングワッシャー	Spring washer	4				
M140	W008	ワッシャー	Washer	4				
M141	W0B8	"	"	4				
M142	5100-1	大押え駆動シャフト取付台 (B)	Main clamp operating shaft base(B)	2				

Fig. 部品番号		部 品 名	Description	個・台 Amt. Req.	共通部品 Common Parts			
No.	Parts. No.							
M143	M830	止めネジ	Screw (for Fig.142)	6				
M144	SW08	スプリングワッシャー	Spring washer	6				
M145	W008	ワッシャー	Washer	6				
M146	5066	油圧シリンダー先端ジョイント取付金具土台止板	Base plate	1				
M147	M820	止めネジ	Screw (for Fig.146)	4				
M148	SW08	スプリングワッシャー	Spring washer	4				
M149	W008	ワッシャー	Washer	4				
M150	5067	油圧シリンダー先端ジョイント取付金具土台	Set base (A)	1				
M151	M820	止めネジ	Screw (for Fig.150)	2				
M152	SW08	スプリングワッシャー	Spring washer	2				
M153	W008	ワッシャー	Washer	2				
M154	5068	油圧シリンダー先端ジョイント取付金具	Set base (B)	1				
M155	M820	止めネジ	Screw (for Fig.154)	2				
M156	SW08	スプリングワッシャー	Spring washer	2				
M157	W008	ワッシャー	Washer	2				
M158	5113	油圧シリンダー先端ジョイント	Joint	1				
M159	5069	油圧シリンダー止金具土台(前)	Base (forward)	1				
M160	M820	止めネジ	Screw (for Fig.159)	2				
M161	SW08	スプリングワッシャー	Spring washer	2				
M162	W008	ワッシャー	Washer	2				
M163	5070	油圧シリンダー止金具(前)	Cylinder set plate (forward)	2				
M164	M820	止めネジ	Screw (for Fig.163)	2				
M165	SW08	スプリングワッシャー	Spring washer	2				
M166	W008	ワッシャー	Washer	2				
M167	5072	油圧シリンダー止金具土台(後)	Base (rear)	1				
M168	M615	止めネジ	Screw (for Fig.167)	2				
M169	SW06	スプリングワッシャー	Spring washer	2				
M170	W006	ワッシャー	Washer	2				
M171	5071	油圧シリンダー止金具(後)	Cylinder set plate (rear)	1				
M172	M620	止めネジ	Screw (for Fig.171)	2				
M173	WOB6	ワッシャー	Washer	2				
M174	WOS6	ワッシャー	Washer	2				
M175	SW06	スプリングワッシャー	Spring washer	2				
M176	N006	ナット	Nut	2				

三角メス機構

Tab knife mechanism

[N]

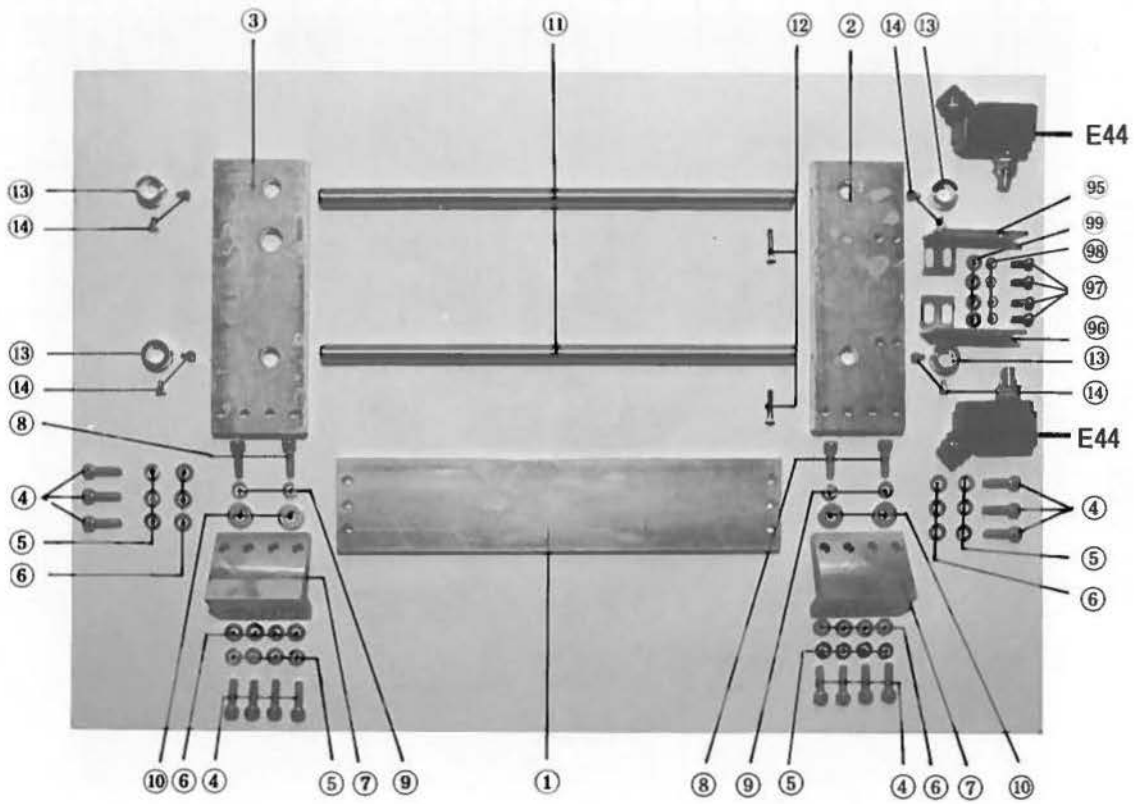

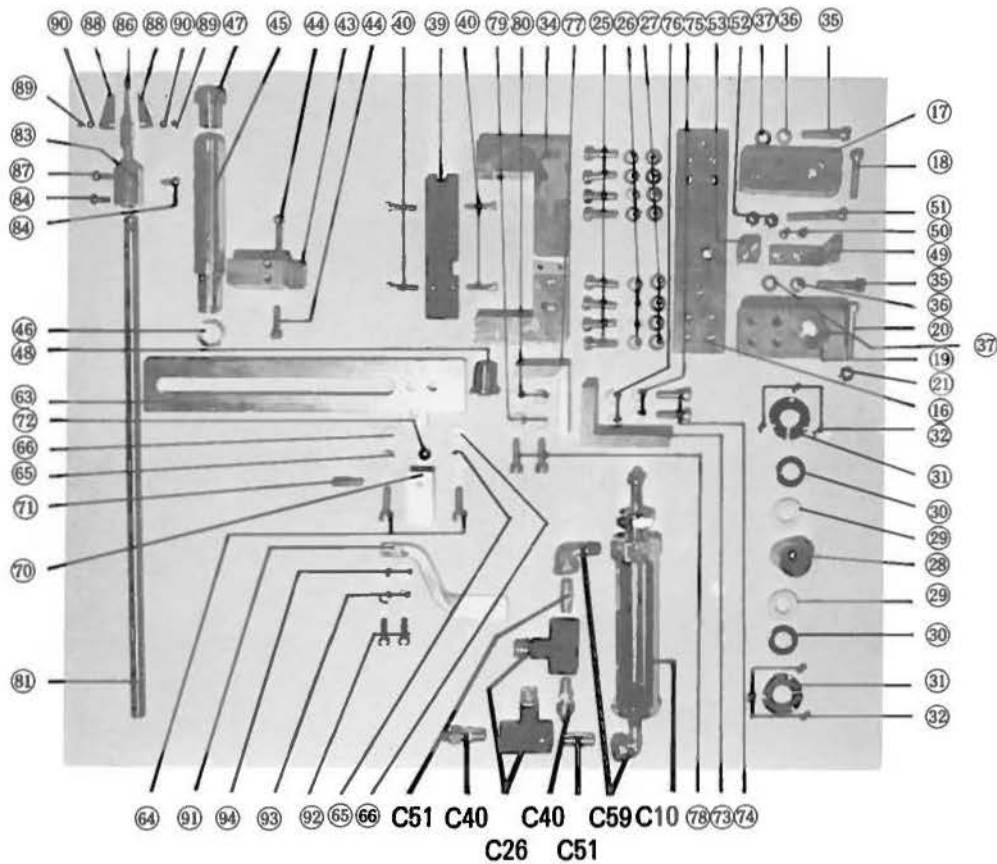
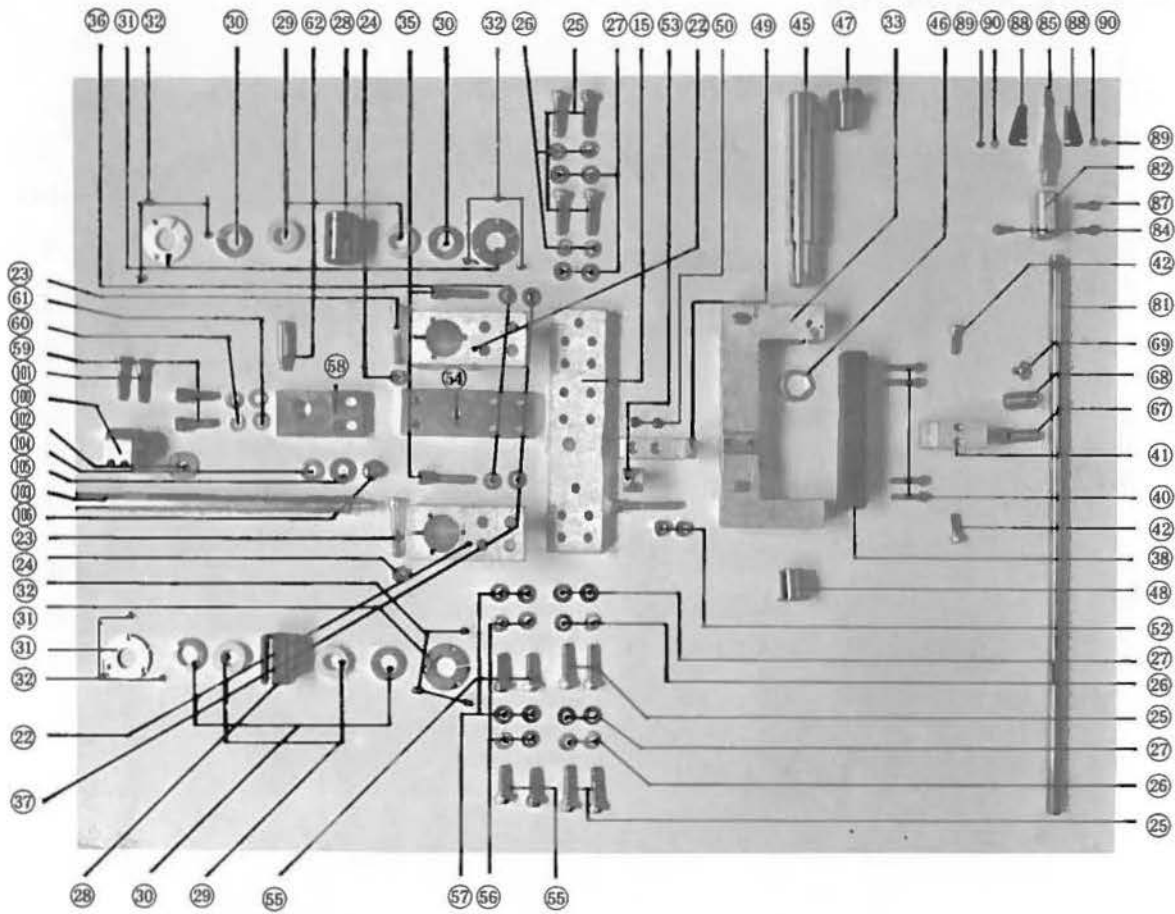



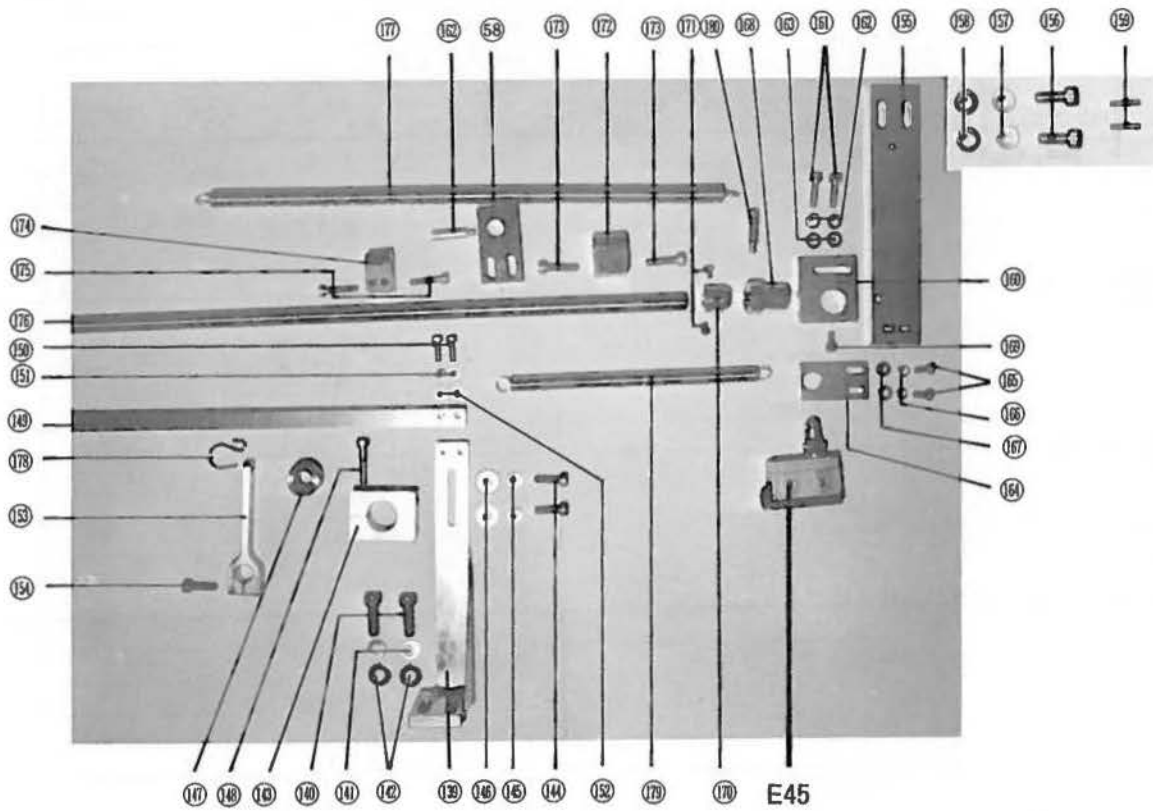
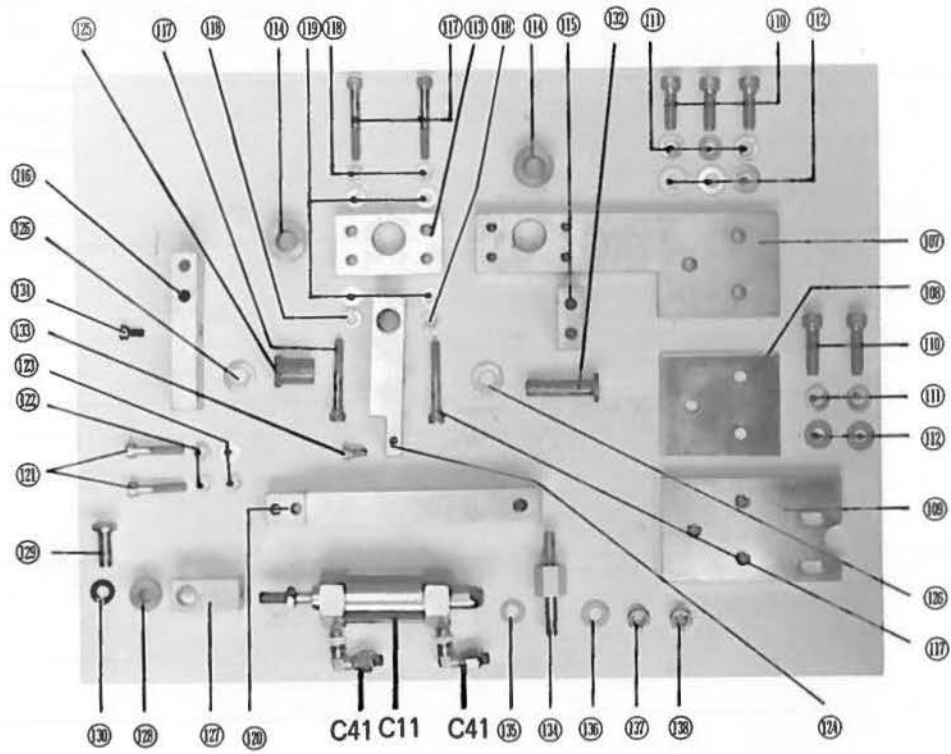

Fig. No.	部品番号 Parts. No.	部 品 名	Description	個・台 Amt. Req.	共通部品 Common Parts			
N 1	4001	三角メスブロック本体 (C)	Tab knife block base (C)	1				
N 2	4002	" (A)	" (A)	1				
N 3	4003	" (B)	" (B)	1				
N 4	M625	止めネジ	Screw (for Fig.1, 2, 3)	14				
N 5	SW06	スプリングワッシャー	Spring washer	14				
N 6	WOS6	ワッシャー	Washer	14				
N 7	4004	三角メスブロック本体止板	Set base	2				
N 8	M625	止めネジ	Screw (for Fig.7)	4				
N 9	SW06	スプリングワッシャー	Spring washer	4				
N10	WOB6	ワッシャー	Washer	4				
N11	4005	三角メス本体シャフト	Base shaft	2				
N12	M425	止めネジ	Screw (for Fig.11)	2				
N13	4018	カラー	Collar	4				
N14	M405	止めネジ	Screw (for Fig.13)	8				
N15	4006	三角メス棒土台止板 (前)	Tab knife shaft base plate(forward)	1				
N16	4007	" (後)	" (rear)	1				
N17	4010	三角メス棒土台軸受 (後)	Shaft case (rear)	1				
N18	M625	止めネジ	Screw	1				
N19	4010-1	三角メス棒土台軸受ベアリングケース(後)	Bearing case (rear)	1				
N20	M640	止めネジ	Screw (for Fig.19)	1				
N21	N006	ナット	Nut	1				
N22	4008	三角メス棒土台軸受ベアリングケース(前)	Bearing case (forward)	2				
N23	M640	止めネジ	Screw (for Fig.22)	2				
N24	N006	ナット	Nut	2				
N25	M625	止めネジ	Screw (for Fig.17,19,22)	16				
N26	SW06	スプリングワッシャー	Spring washer	16				
N27	WOS6	ワッシャー	Washer	16				
N28	4069	ベアリング13%	Bearing 13%	3				
N29	4071	フェルト	Felt	6				
N30	4071-1	フェルト止	Felt stoper ring	6				
N31	4069-1	ベアリング止リング	Bearing stoper ring	6				
N32	M306	止めネジ	Screw (for Fig.31)	18				
N33	4011F	三角メス棒土台 (前)	Tab knife shaft support plate(forward)	1				
N34	4011R	" (後)	" (rear)	1				
N35	M630	止めネジ	Screw (for Fig.33,34)	4				
N36	SW06	スプリングワッシャー	Spring washer	4				
N37	W006	ワッシャー	Washer	4				
N38	4012F	三角メス棒ダキスライド土台(前)	Slide base (forward)	1				
N39	4012R	" (後)	" (rear)	1				
N40	M420	止めネジ	Screw (for Fig.38,39)	8				
N41	4014	三角メス棒ダキ (前)	Shaft holder (forward)	1				
N42	M515	止めネジ	Screw (for Fig.41)	2				
N43	4013	三角メス棒ダキ (後)	Shaft holder (rear)	1				
N44	M520	止めネジ	Screw (for Fig.43)	2				
N45	4016	三角メス棒土台パイプ	Base pipe	2				
N46	4016-N	ナット	Nut	2				
N47	4016-1	三角メス棒土台パイプメタル上	Bushing (upper)	2				
N48	4017	" 下	" (under)	2				
N49	4019	三角メス左右調節腕	Regulator arm	2				
N50	SM15	止めネジ	Screw (for Fig.49)	4				
N51	4020	三角メス左右調節ネジ	Regulator screw	2				
N52	N006	ナット	Nut	4				
N53	4021	三角メス左右調節ネジガイド	Regulator screw guido	2				
N54	4022	三角メス棒土台引張板 (A)	Plate (A)	1				
N55	M620	止めネジ	Screw (for Fig.54)	4				

Fig. No.	部品番号 Parts. No.	部 品 名	Description	個・台 Amt. Req.	共通部品 Common Parts			
N56	SW06	スプリングワッシャー	Spring washer	4				
N57	WOS6	ワッシャー	Washer	4				
N58	4023	三角メス棒土台引張板 (B)	Plate (B)	1				
N59	M620	止めネジ	Screw (for Fig.58)	2				
N60	SW06	スプリングワッシャー	Spring washer	2				
N61	WOS6	ワッシャー	Washer	2				
N62	5107	バネ止め金具	Spring set pin	1				
N63	4024	三角メス上下案内腕	Guide arm	1				
N64	M620	止めネジ	Screw (for Fig.63)	2				
N65	SW06	スプリングワッシャー	Spring washer	2				
N66	WOS6	ワッシャー	Washer	2				
N67	4026	案内腕上下用芯棒	Guide arm centerpin	1				
N68	4027	ローラー	Roller	1				
N69	SM02	丸平ネジ	Screw	1				
N70	4028	三角メスシリンダー先端金具	Cylinder supporting braket	1				
N71	4029	ピン	Pin	1				
N72	N006	ナット	Nut	1				
N73	4030	三角メスシリンダー止板 (A)	Set plate	1				
N74	M620	止めネジ	Screw (for Fig.73)	2				
N75	SW06	スプリングワッシャー	Spring washer	2				
N76	WOS6	ワッシャー	Washer	2				
N77	4031	三角メスシリンダー止板 (B)	Set plate	1				
N78	M620	止めネジ	Screw (for Fig.77)	2				
N79	SW06	スプリングワッシャー	Spring washer	2				
N80	WOS6	ワッシャー	Washer	2				
N81	4032	三角メス棒	Tab knife bar	2				
N82	4033F	三角メス刃取付台止カップリング(前)	Cap ring (forward)	1				
N83	4033R	" (後)	" (rear)	1				
N84	M410	止めネジ	Screw (for Fig.82,83)	4				
N85	4035F	三角メス刃土台 (前)	Tab knife base (forward)	1				
N86	4035R	" (後)	" (rear)	1				
N87	M410	止めネジ	Screw (for Fig.85,86)	2				
N88	4034	三角メス刃	Tab knife	4				
N89	SM23	止めネジ	Screw (for Fig.88)	4				
N90	W002	ワッシャー	Washer	4				
N91	4036	三角メススイッチ当て板	Limit switch connecting plate	1				
N92	M520	止めネジ	Screw (for Fig.91)	2				
N93	SW05	スプリングワッシャー	Spring washer	2				
N94	W005	ワッシャー	Washer	2				
N95	4037	スイッチ止板 (上)	Limit switch set plate (upper)	1				
N96	4038	" (下)	" (under)	1				
N97	M515	止めネジ	Screw (for Fig.95,96)	4				
N98	SW05	スプリングワッシャー	Spring washer	4				
N99	W005	ワッシャー	Washer	4				
N100	4062	三角メス棒土台位置止りシャフトカラー	Collar	1				
N101	M625	止めネジ	Screw (for Fig.100)	2				
N102	GO13	クッションリング	Rubber ring	1				
N103	4072	三角メス棒土台位置止りシャフト	Shaft	1				
N104	W008	ワッシャー	Washer	1				
N105	SW08	スプリングワッシャー	Spring washer	1				
N106	N008	ナット	Nut	1				
N107	4040	三角メス位置決め取付台	Tab knife position adjusting setbasu	1				
N108	4040-2	スペーサー	Spacer	1				
N109	4040-1	三角メス位置決め取付台止板	Set plate	1				
N110	M825	止めネジ	Screw (for Fig.109)	5				

Fig. No.	部品番号 Parts, No.	部 品 名 Description	個・台 Amt. Req.	共通部品 Common Parts			
N111	SW08	スプリングワッシャー	Spring washer	5			
N112	W008	ワッシャー	Washer	5			
N113	4041	三角メス位置決め取付ベース (A)	Base (A)	1			
N114	4046	メタル	Bushing	2			
N115	4042	三角メス位置決め取付ベース (B)	Base (B)	1			
N116	4043	" (C)	" (C)	1			
N117	M645	止めネジ	Screw (for Fig.113)	4			
N118	SW06	スプリングワッシャー	Spring washer	4			
N119	WOS6	ワッシャー	Washer	4			
N120	4044	位置決めシリンダー取付台	Cylinder set base	1			
N121	M630	止めネジ	Screw (for Fig.120)	2			
N122	SW06	スプリングワッシャー	Spring washer	2			
N123	W006	ワッシャー	Washer	2			
N124	4045	三角メス位置決め軸固定腕	Shaft set arm	1			
N125	4045-1	メタル	Bushing	1			
N126	WBSP10	ワッシャー	Washer	1			
N127	4049	三角メス位置決めシリンダー先端金具	Cylinder supporting bracket	1			
N128	4048	メタル	Bushing	1			
N129	4050	ピン	Pin	1			
N130	WBSP8	ワッシャー	Washer	1			
N131	M510	止めネジ	Screw (for Fig.130)	1			
N132	4051	三角メス位置決め軸固定腕止ピン	Set pin	1			
N133	M510	止めネジ	Screw (for Fig.132)	1			
N134	4052	三角メス位置決めシリンダー止めピンネジ	Cylinder set pin screw	1			
N135	WBSP8	ワッシャー	Washer	1			
N136	W008	"	"	1			
N137	N008	ナット	Nut	1			
N138	NK08	"	"	1			
N139	4055	三角メス位置決め駆動軸前軸受メタルボックス土台	Bushing box base	1			
N140	M820	止めネジ	Screw (for Fig.139)	2			
N141	SW08	スプリングワッシャー	Spring washer	2			
N142	W008	ワッシャー	Washer	2			
N143	4054	三角メス位置決め駆動軸前メタルボックス	Bushing box	1			
N144	M620	止めネジ	Set screw	2			
N145	SW06	スプリングワッシャー	Spring washer	2			
N146	WOB6	ワッシャー	Washer	2			
N147	4054-1	三角メス位置決め駆動軸前メタル	Bushing	1			
N148	M630	止めネジ	Set screw	1			
N149	4056	三角メス位置決め軸引バネ金具スラスト棒	Thrust bar	1			
N150	M515	止めネジ	Set screw	2			
N151	SW05	スプリングワッシャー	Spring washer	2			
N152	W005	ワッシャー	Washer	2			
N153	4057	三角メス位置決め軸引バネ金具	Spring set base	1			
N154	M620	止めネジ	Set screw	1			
N155	4063	三角メス位置決め駆動軸後ストッパー止板取付台	Set base	1			
N156	M620	止めネジ	Set screw	2			
N157	SW06	スプリングワッシャー	Spring washer	2			
N158	WOB6	ワッシャー	Washer	2			
N159	P310	ノックピン	Nock pin	2			
N160	4064	三角メス位置決め駆動軸後ストッパー止板	Set plate	1			
N161	M620	止めネジ	Set screw	2			
N162	SW06	スプリングワッシャー	Spring washer	2			
N163	WOS6	ワッシャー	Washer	2			
N164	4065	三角メス位置決め軸スイッチ取付板	Limit switch set plate	1			
N165	M515	止めネジ	Screw (for Fig.164)	2			

Fig. 部品番号		部 品 名	Description	個・台 Amt. Req.	共通部品 Common Parts			
No.	Parts. No.							
N 166	SW05	スプリングワッシャー	Spring washer	2				
N 167	W005	ワッシャー	Washer	2				
N 168	4068	三角メス位置決め軸前軸受	Shaft receiver	1				
N 169	M510	止めネジ	Screw (for Fig.168)	1				
N 170	4067	三角メス位置決めスイッチ押え金具	Limit switch activation collar	1				
N 171	M410	止めネジ	Screw	2				
N 172	4061	三角メス位置決め駆動軸カラー (A)	Collar (A)	1				
N 173	M620	止めネジ	Screw (for Fig.172)	2				
N 174	4062	三角メス位置決め駆動軸カラー (B)	Collar (B)	1				
N 175	M520	止めネジ	Screw (for Fig.174)	2				
N 176	4059	三角メス位置決め駆動軸	Shaft	1				
N 177	4058	三角メス位置決め軸引バネ	Spring	1				
N 178	5107-1	バネ先端金具 S 管	Buraket	1				
N 179	4023-1	三角メス棒土台引バネ	Spring	1				
N 180	5107	バネ止め金具	Spring set pin	1				
N 85	4035F	三角メス刃土台前10%ゲージ用	Tab knife base(forward)10%gauge					
N 86	4035R	後 "	" (rear) "					
N 85	4035F1	前12%ゲージ用	" (forward)12%gauge					
N 86	4035R1	後 "	" (rear) "					
N 85	4035F2	前8%ゲージ用	" (forward)8%gauge					
N 86	4035R2	後 "	" (rear) "					
N 85	4035F3	前14%ゲージ用	" (forward)14%gauge					
N 86	4035R3	後 "	" (rear) "					
N 85	4035F4	前16%ゲージ用	" (forward)16%gauge					
N 86	4035R4	後 "	" (rear) "					
N 85	4035F5	前18%ゲージ用	" (forward)18%gauge					
N 86	4035R5	後 "	" (rear) "					
N 85	4035F6	前20%ゲージ用	" (forward)20%gauge					
N 86	4035R6	後 "	" (rear) "					

本体機構 [A]  
 Frame mechanism

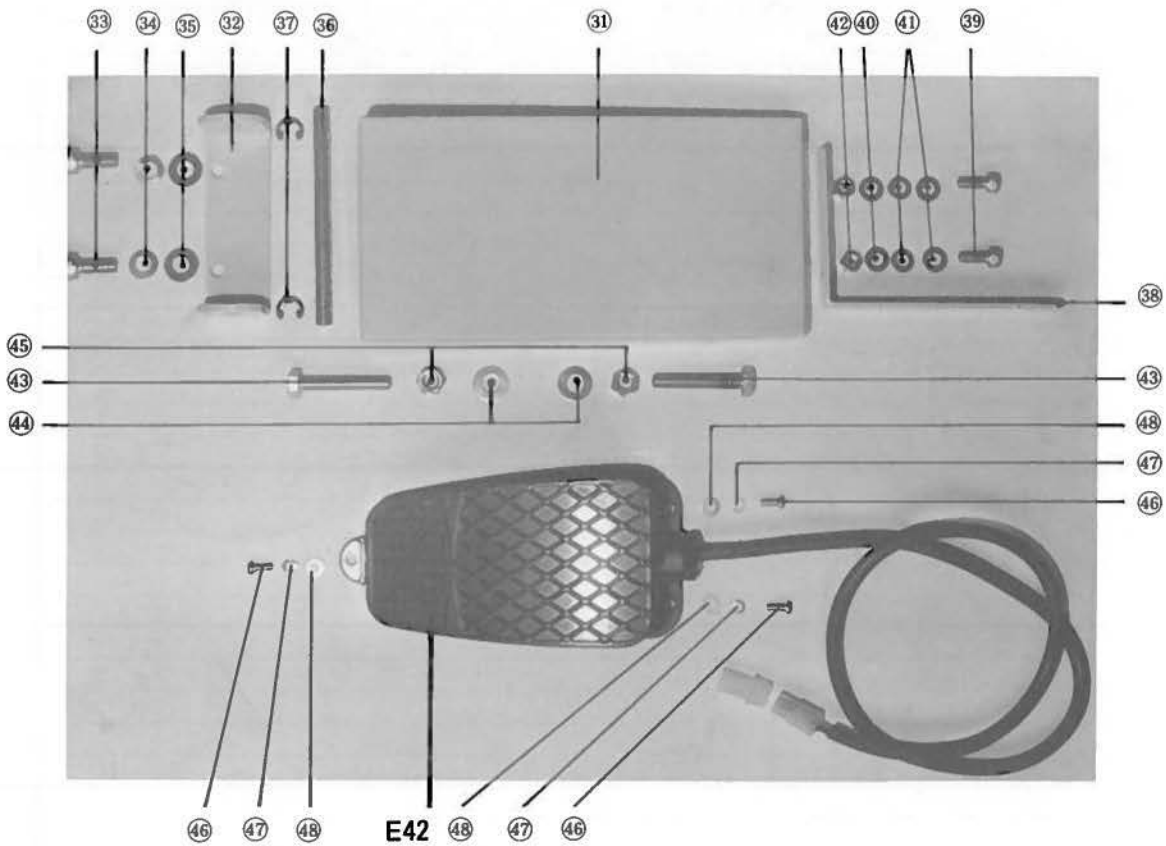
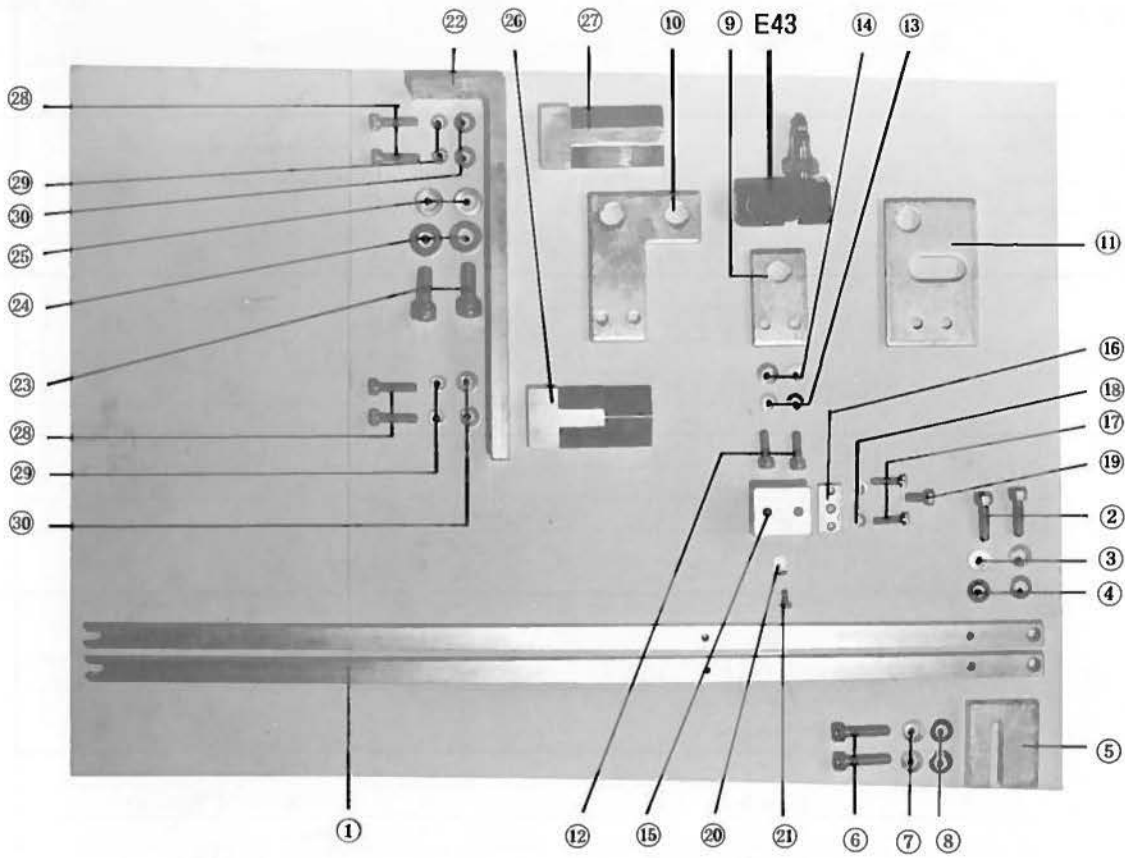

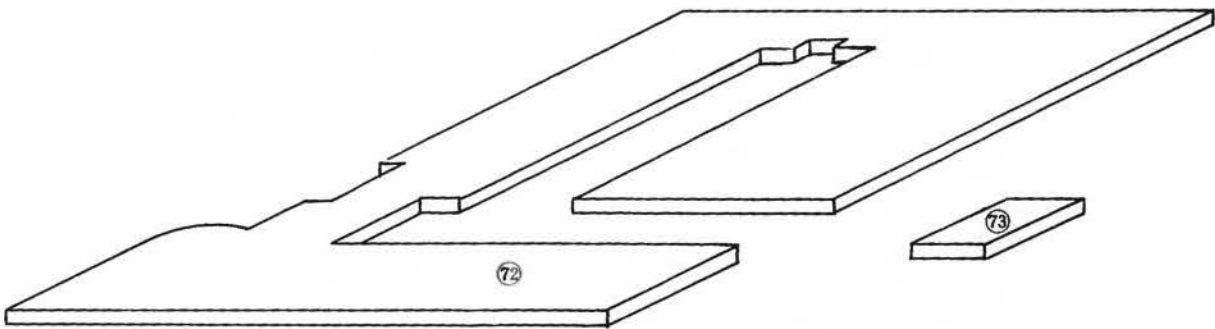
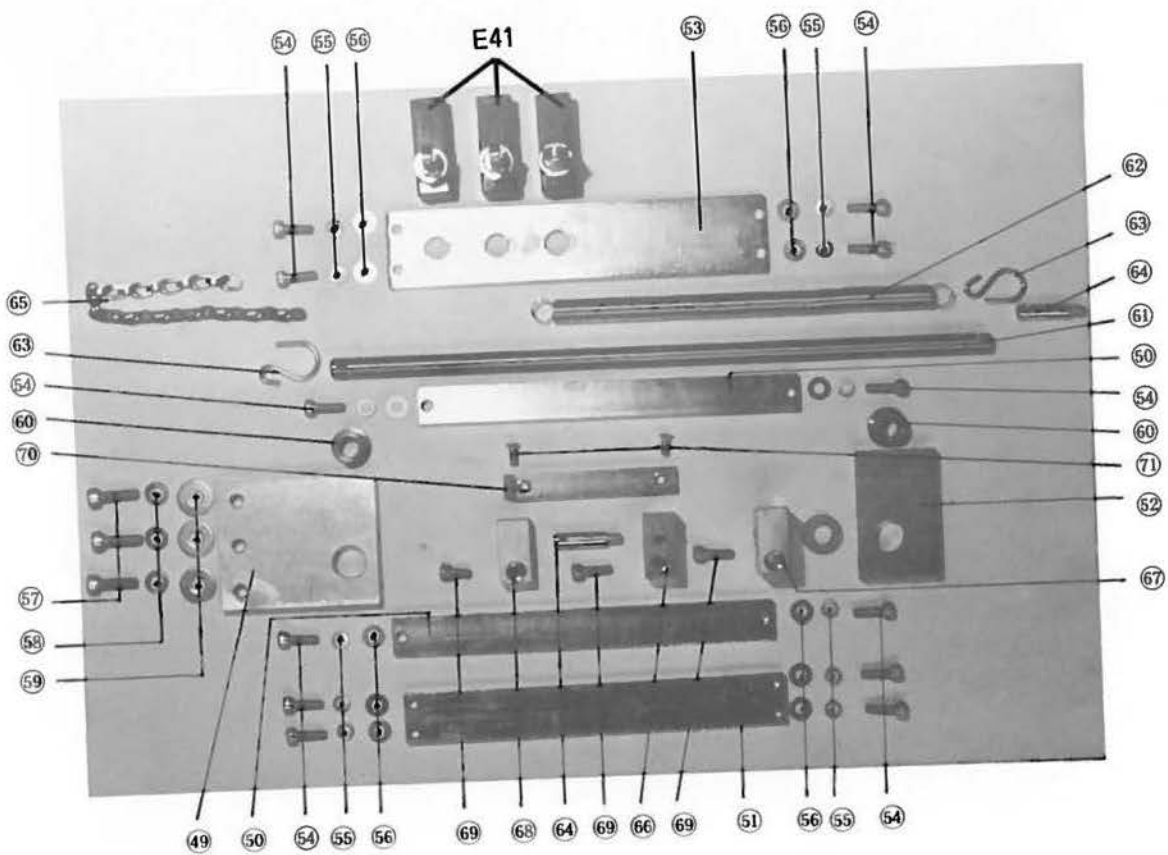

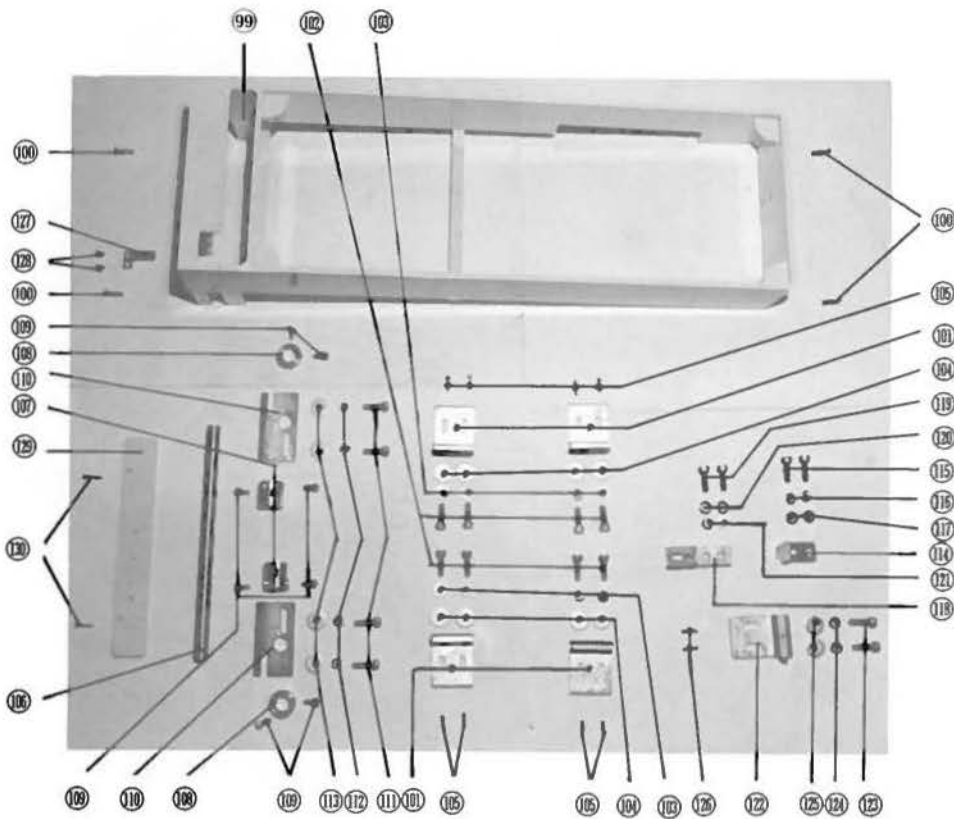
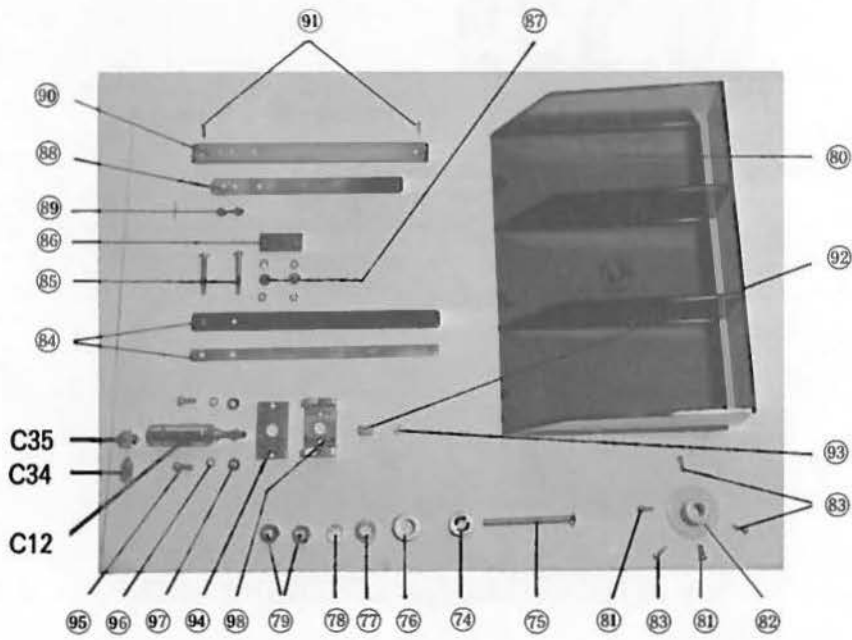



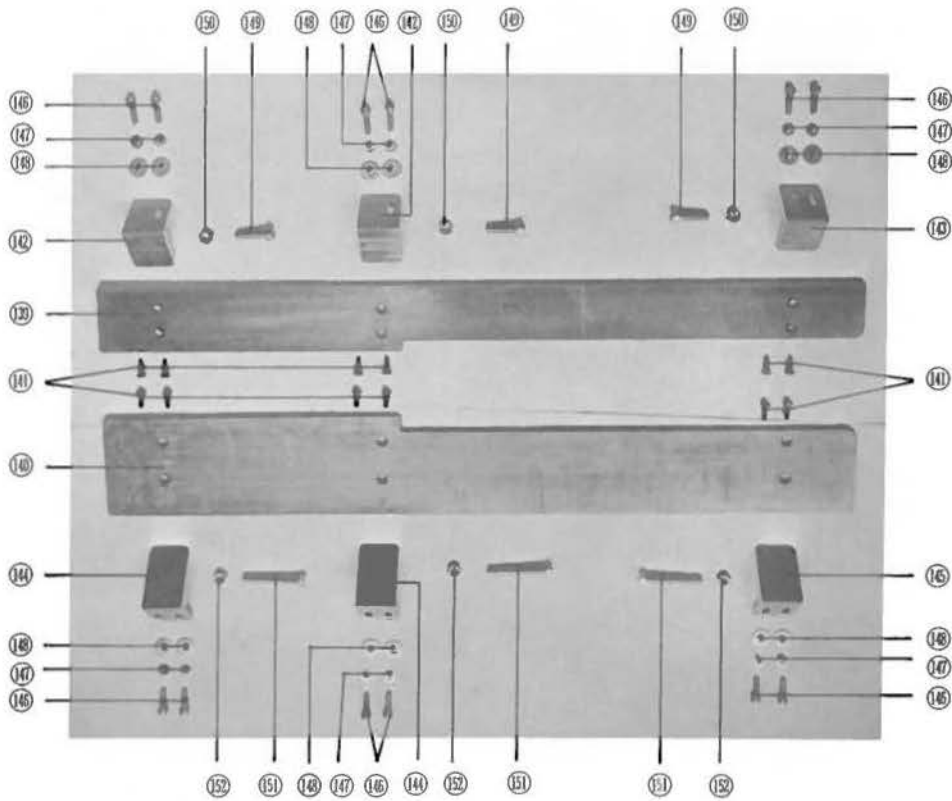
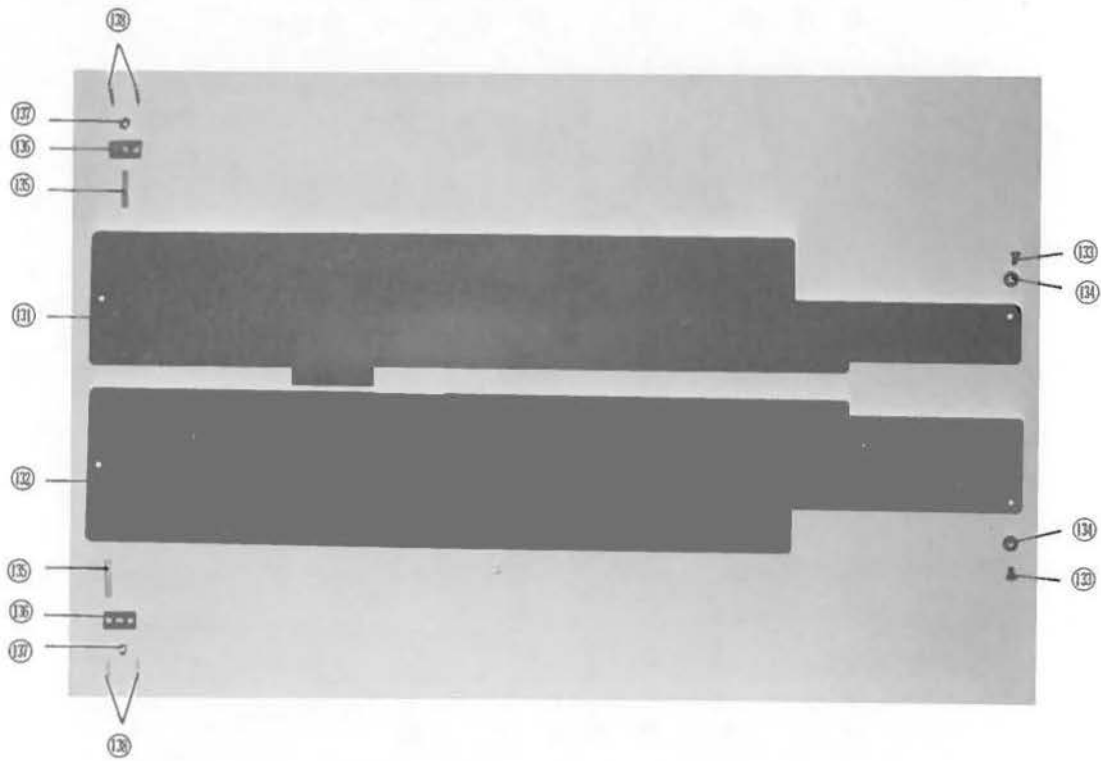

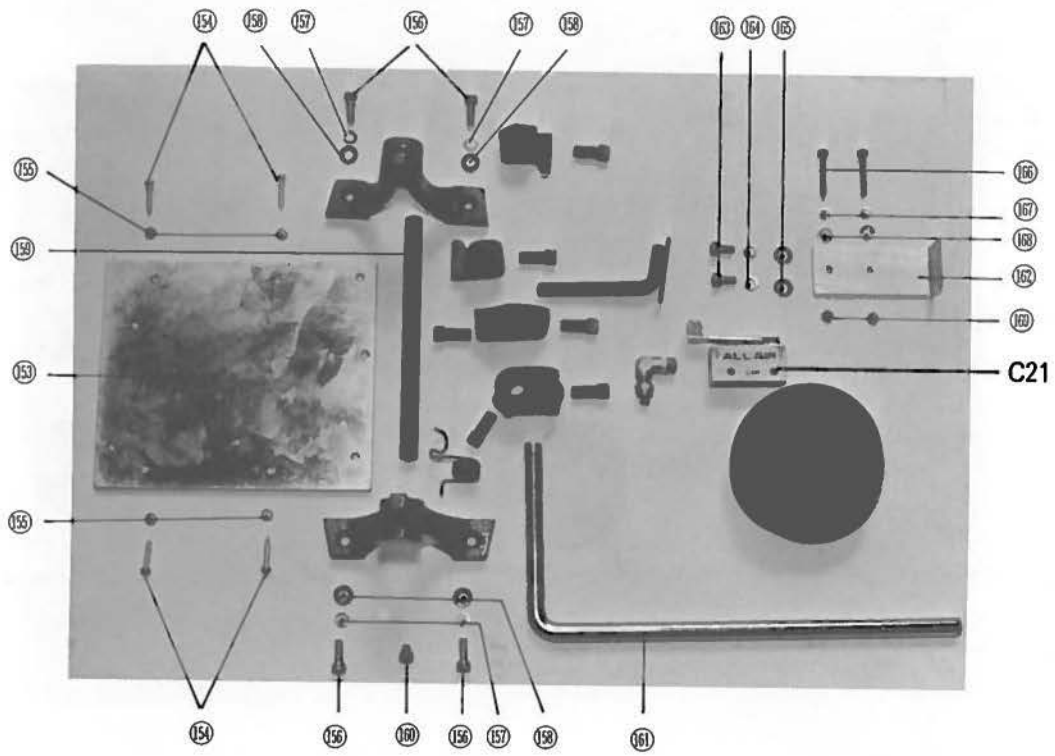

Fig. No.	部品番号 Parts. No.	部 品 名	Description	個・台 Amt. Req.	共通部品 Common Parts			
A 1	5051	リミットスイッチ取付軸	Limit swichi mounting bar	4				
A 2	M625	止めネジ	Set screw	8				
A 3	SW06	スプリングワッシャー	Spring washer	8				
A 4	W006	ワッシャー	Washer	8				
A 5	5052	スイッチ台取付軸土台	Base (for Fig. 1)	4				
A 6	M625	止めネジ	Set screw	8				
A 7	SW06	スプリングワッシャー	Spring washer	8				
A 8	W006	ワッシャー	Washer	8				
A 9	5053	リミットスイッチ止板	Limit switch set plate	3				
A 10	5053-1	"	"	4				
A 11	5053-2	"	"	2				
A 12	M510	止めネジ	Set screw	18				
A 13	SW05	スプリングワッシャー	Spring washer	18				
A 14	W005	ワッシャー	Washer	18				
A 15	5054	リミットスイッチ止板台	Base (for Fig. 9)	9				
A 16	5055	" 止金具	Set plate (for Fig.15)	9				
A 17	M415	止めネジ	Set screw	18				
A 18	SW04	スプリングワッシャー	Spring washer	18				
A 19	M510	止めネジ	Set screw	9				
A 20	5056	目盛基点板	Mark plate	9				
A 21	SM18	止めネジ	Set screw	9				
A 22	5058	リミットスイッチドック取付台	Set base	1				
A 23	M820	止めネジ	Set screw	2				
A 24	SW08	スプリングワッシャー	Spring washer	2				
A 25	W008	ワッシャー	Washer	2				
A 26	5057	リミットスイッチドック (下)	Switch activation (under)	1				
A 27	5057-1	" (上)	" (uper)	1				
A 28	M520	止めネジ	Set screw	4				
A 29	SW05	スプリングワッシャー	Spring washer	4				
A 30	W005	ワッシャー	Washer	4				
A 31	5078	踏み板	Foot pedal	1				
A 32	5079	踏み板受け台	Base (for Fig.31)	1				
A 33	M620	止めネジ	Set screw	2				
A 34	SW06	スプリングワッシャー	Spring washer	2				
A 35	W006	ワッシャー	Washer	2				
A 36	5080	踏み板シャフト	Foot pedal base shaft	1				
A 37	5080-1	止めリング	Retaining rings	2				
A 38	5081	踏み板L型金具	Foot pedal "L" shaped braket	1				
A 39	M615	止めネジ	Set screw	2				
A 40	SW06	スプリングワッシャー	Spring washer	2				
A 41	W006	ワッシャー	Washer	2				
A 42	N006	ナット	Nut	2				
A 43	B840	高さ調節ネジ	Regulatar screw	2				
A 44	W008	ワッシャー	Washer	2				
A 45	N008	ナット	Nut	2				
A 46	M410	止めネジ	Set screw	3				
A 47	SW04	スプリングワッシャー	Spring washer	3				
A 48	W004	ワッシャー	Washer	3				
A 49	5087	踏み板スイッチ用ブロック (C)	Foot pedal switch blok (C)	1				
A 50	5085	" (A)	" (A)	2				
A 51	5086	" (B)	" (B)	1				
A 52	5088	" (D)	" (D)	1				
A 53	5095	踏み板スイッチ止用ブロック (E)	" (E)	1				
A 54	M515	止めネジ	Set screw	12				
A 55	SW05	スプリングワッシャー	Spring washer	12				

Fig. No.	部品番号 Parts. No.	部 品 名	Description	個・台 Amt. Req.	共通部品 Common Parts			
A 56	W005	ワッシャー	Washer	12				
A 57	M620	踏み板スイッチ用ブロック止ネジ	Set screw	3				
A 58	SW06	スプリングワッシャー	Spring washer	3				
A 59	WOB6	ワッシャー	Washer	3				
A 60	5089	踏み板スイッチ用ブロック(CID)用メタル	Bushing (for Fig.49,52)	2				
A 61	5090	踏み板スイッチ用シャフト	Shaft	1				
A 62	5082	踏み板スイッチ用引バネ	Spring	1				
A 63	5107-1	引バネ先端金具S管	Buraket	2				
A 64	5107	引バネ止め金具	Set pin	2				
A 65	5083	鎖	Chain	1				
A 66	5091	踏み板スイッチ用引バネ止金具	Spring set block	1				
A 67	5092	スイッチアテ板止ブロック A	Switch actuation block (A)	1				
A 68	5093	" B	" (B)	1				
A 69	M515	止めネジ	Set screw	3				
A 70	5094	スイッチアテ板	Switch activation plate	1				
A 71	SM15	丸皿ネジ	Set screw	2				
A 72	5010	テーブル	Table	1				
A 73	5010-1	テーブル補助板	Bobbin winder set table	1				
A 74	5011	テーブル止座金	Washer	16				
A 75	M670S	丸皿ネジ	Screw (for Fig.72)	16				
A 76	WOB8	ワッシャー	Washer	16				
A 77	W006	"	"	16				
A 78	SW06	スプリングワッシャー	Spring washer	16				
A 79	N006	ナット	Nut	32				
A 80	5012	玉布台	Patch welt,Stay,Flap material box	1				
A 81	M410N	止めネジ	Screw (for Fig.80)	2				
A 82	5012-1	玉布台取付金具	Base	1				
A 83	MSW3	丸皿ネジ	Screw (for Fig.82)	3				
A 84	5109	袋生地押えバネ (巾広)	Inside poket moterial set spring(wide)	1				
"	5109-1	" (巾狭)	" (narrow)					
A 85	5108	止めネジ	Screw (for Fig.84)	2				
A 86	5108-1	ネジ止め板	Set plate	1				
A 87	M004	ナット	Nut	2				
A 88	5043	袋生地押えバネ (左)	Inside poket material set spring(left)	1				
A 89	5043-1	止めネジ	Screw (for Fig.88)	2				
A 90	5044	袋生地押え取り付け板	Set plate	1				
A 91	MSW1	丸皿ネジ	Screw (for Fig.90)	2				
A 92	3030A	袋押えシリンダー先端金具	Cylinder supporting bracket	1				
A 93	3031	" テフロン	Teflon	1				
A 94	5039	袋押えシリンダー取り付け板	Set plate	1				
A 95	M410N	止めネジ	Screw	2				
A 96	SW04	スプリングワッシャー	Spring washer	2				
A 97	W004	ワッシャー	Washer	2				
A 98	5038	袋押えシリンダー取り付け板土台	Base	1				
A 99	5027	頭部取り付け枠	Frame(for sewing machine)	1				
A 100	M515S	丸皿ネジ	Set screw(for sewing machine)	4				
A 101	5028	頭部取り付け枠止め金具	Set base	4				
A 102	M620	止めネジ	Screw (for Fig. 101)	8				
A 103	SW06	スプリングワッシャー	Spring washer	8				
A 104	WOB6	ワッシャー	Washer	8				
A 105	P310	ノックピン	Nock pin	8				
A 106	5029	頭部取り付け枠シャフト	Shaft	1				
A 107	5030	" カラー (B)	Collar (B)	2				
A 108	5031	" " (A)	" (A)	2				
A 109	M510	止めネジ	Screw (for Fig.107,108)	8				

Fig. No.	部品番号 Parts. No.	部 品 名	Description	個・台 Amt. Req.	共通部品 Common Parts			
A 110	5033	頭部取り付け枠受け板	Set plate	2				
A 111	M615	止めネジ	Screw	4				
A 112	SW06	スプリングワッシャー	Spring washer	4				
A 113	WOB6	ワッシャー	Washer	4				
A 114	5034	頭部取り付け枠位置決め金具 (A)	Position set base (A)	1				
A 115	M615	止めネジ	Screw (for Fig.114)	2				
A 116	SW06	スプリングワッシャー	Spring washer	2				
A 117	W006	ワッシャー	Washer	2				
A 118	5035	頭部取り付け枠位置決め金具 (B)	Posisio set base (B)	1				
A 119	M615	止めネジ	Screw (for Fig.118)	2				
A 120	SW06	スプリングワッシャー	Spring washer	2				
A 121	W006	ワッシャー	Washer	2				
A 122	5032	頭部取り付け枠位置決め金具(B)取付台	Set base (for Fig.118)	1				
A 123	M615	止めネジ	Screw (for Fig.122)	2				
A 124	SW06	スプリングワッシャー	Spring washer	2				
A 125	W006	ワッシャー	Washer	2				
A 126	P310	ノックピン	Nock pin	2				
A 127	5020	エアパイプ止板	Air pipe set plate	1				
A 128	SM18	丸平ネジ	Screw (for Fig.127)	2				
A 129	5018	下糸巻止め板	Bobbin winder set plate	1				
"	SM02	下糸巻止めネジ	Screw (for bobbin winder)	2				
A 130	MSW1	丸皿ネジ	Screw (for Fig.129)	2				
A 131	5013L	大押え下板 (左)	Main clamp lower plate(left)	1				
A 132	5013R	" (右)	" (right)	1				
A 133	SM25	段付平ネジ	Screw (for Fig.131,132)	2				
A 134	SW25	ワッシャー	Washer	2				
A 135	5111	スベリ板位置決めピン	Pin	2				
A 136	5111-1	スベリ板位置決めピン止板	Set plate	2				
A 137	N004	ナット	Nut	2				
A 138	MSW4	丸皿ネジ	Screw (for Fig.136)	4				
A 139	5014L	大押え下板ベース板 (左)	Base plate(left)	1				
A 140	5014R	" (右)	" (right)	1				
A 141	SM24	止めネジ	Screw (for Fig.139,140)	12				
A 142	5015B	ベース板取付金具左 (A)	Base (for Fig.139) A	2				
A 143	5015B1	" 左 (B)	" ( " ) B	1				
A 144	5015A	" 右 (A)	" (for Fig.140) A	2				
A 145	5015A1	" 右 (B)	" ( " ) B	1				
A 146	M615	止めネジ	Screw (for Fig.142,143,144,145)	12				
A 147	SW06	スプリングワッシャー	Spring washer	12				
A 148	WOB6	ワッシャー	Washer	12				
A 149	M830	高さ調節ネジ (左)	Regulatar screw (left)	3				
A 150	N008	ナット	Nut	3				
A 151	M855B	高さ調節ネジ (右)	Regulatar screw (right)	3				
A 152	N008	ナット	Nut	3				
A 153	5040	膝上げスイッチ取付板	Knee lifter set plate	1				
A 154	MSW2	丸平ネジ	Screw	4				
A 155	SW04	スプリングワッシャー	Spring washer	4				
A 156	M510	止めネジ	Screw (for knee lifter)	4				
A 157	SW05	スプリングワッシャー	Spring washer	4				
A 158	W005	ワッシャー	Washer	4				
A 159	5040-1	シャフト	Shaft	1				
A 160	M510	止めネジ	Screw	1				
A 161	5040-2	膝当て取付棒	Knee put set ber	1				
A 162	5042	エアスイッチ取り付け板	Set plate (for air switch)	1				
A 163	M510	止めネジ	Screw	2				



スタッカー機構(上着用) [S]  
 Stacker mechanism(for coats)

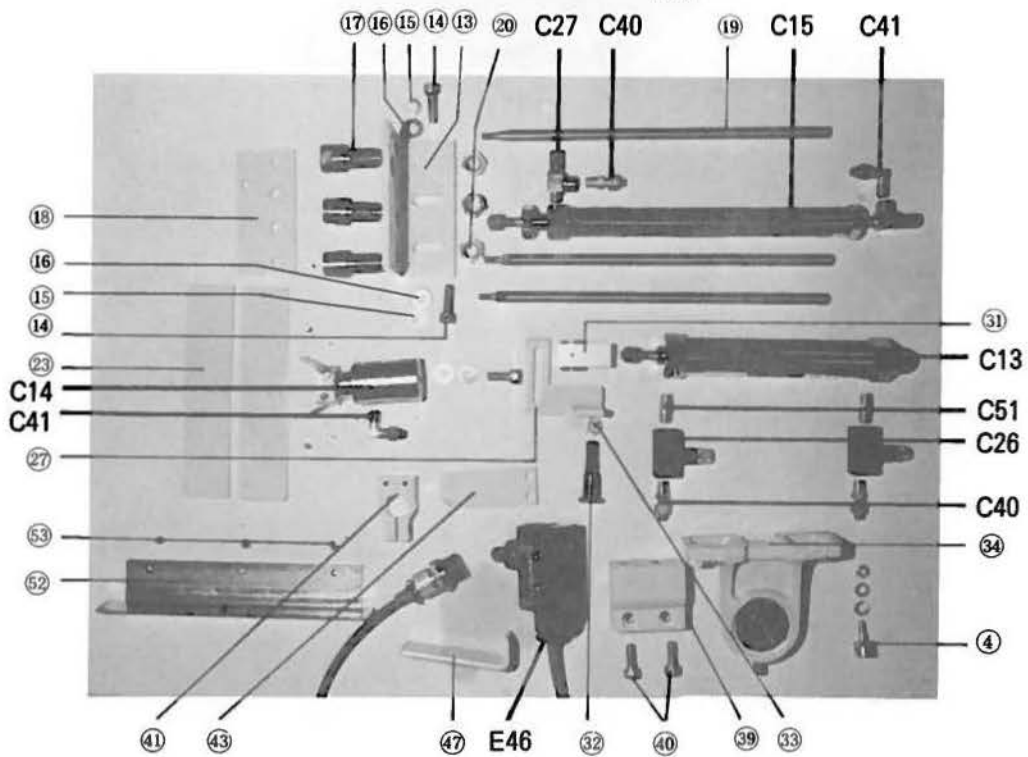
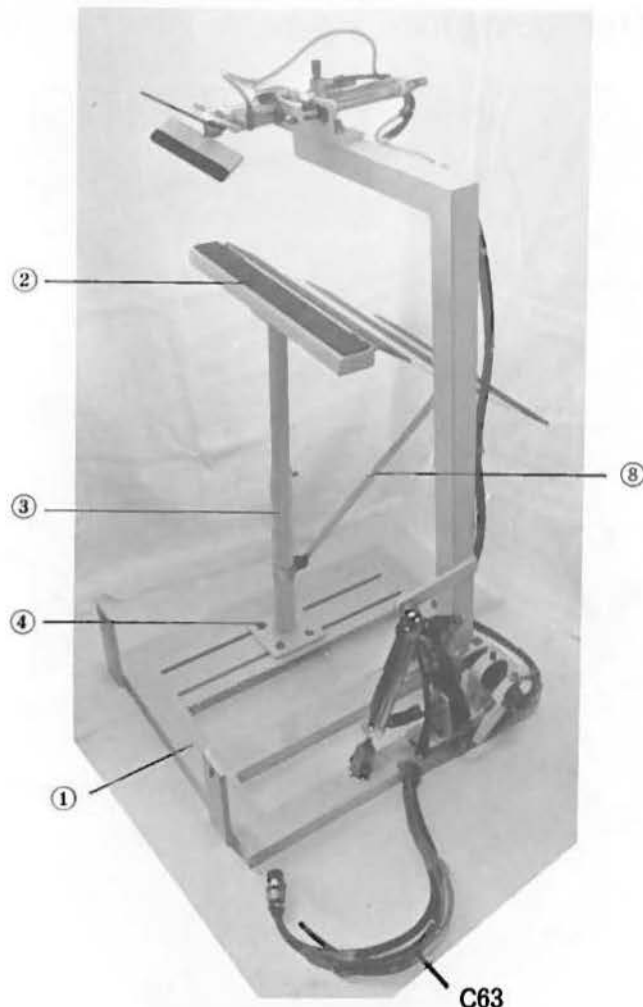

スタッカー機構(スラックス用) [S]  
Stacker mechanism(for coats)

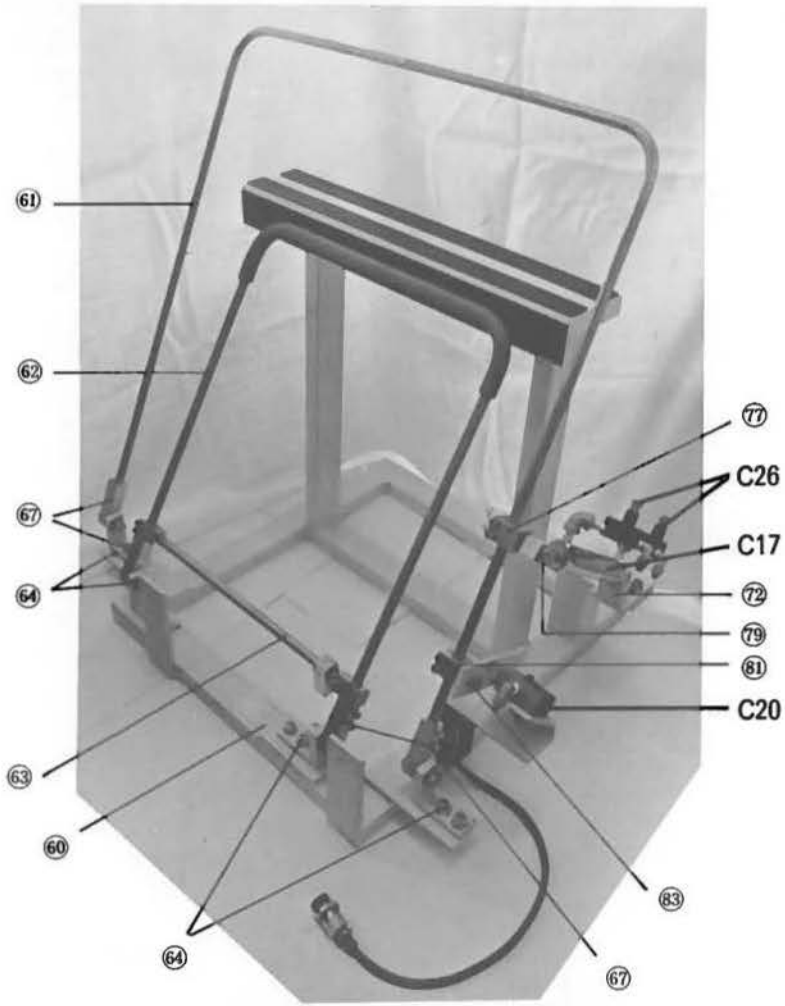



Fig. No.	部品番号 Parts. No.	部 品 名	Description	個・台 Amt. Req.	共通部品 Common Parts			
S 1	6001	スタッカー本体 (上着用)	Stacker base (for coats)	1				
S 2	6002-1	布受台	Material tray	1				
S 3	6002-2	布受台土台	" base	1				
S 4	6002-3	布受台土台止めネジ	Screw (for Fig. 3)	4				
S 5	N006	ナット	Nut	4				
S 6	SW06	スプリングワッシャー	Spring washer	4				
S 7	W006	ワッシャー	Washer	4				
S 8	6002-4	布受台支え棒	Material tray stay bar	1				
S 9	6002-5	" 止め金具	Set ring (for Fig. 8)	1				
S 10	M620	止めネジ	Screw	2				
S 11	W0B6	ワッシャー	Washer	4				
S 12	N006	ナット	Nut	2				
S 13	6004	スタッカー布摺り取付土台	Material hold set base	1				
"	6004-1	" (ロング用)	" (long)	1				
S 14	M815	止めネジ	Screw	2				
S 15	SW08	スプリングワッシャー	Spring washer	2				
S 16	W008	ワッシャー	Washer	2				
S 17	6006	スタッカー布摺りシャフト用メタル,ナット	Bushing/Nut	2				
"	6006-1	"	" (long)	3				
S 18	6005	スタッカー布摺り取付板	Material holding cylinder set plate	1				
"	6005-1	" (ロング用)	" (long)	1				
S 19	6007	スタッカー布摺りシャフト	Material holding shaft	2				
"	6007-1	" (ロング用)	" (long)	3				
S 20	N006	ナット	Nut	2 (3)				
S 21	SW06	スプリングワッシャー	Spring washer	2 (3)				
S 22	W006	ワッシャー	Washer	4 (6)				
S 23	6008	スタッカー布摺り板	Material holding plate	2				
S 24	M410	止めネジ	Screw	4				
S 25	SW04	スプリングワッシャー	Spring washer	4				
S 26	W004	ワッシャー	Washer	4				
S 27	6015	スタッカー腕シリンダー先端金具止土台	Set base (for Fig.28)	1				
"	6015-1	" (ロング用)	" (long)	1				
S 28	M620	止めネジ	Screw	2				
S 29	SW06	スプリングワッシャー	Spring washer	2				
S 30	W006	ワッシャー	Washer	2				
S 31	6016	スタッカー腕シリンダー先端金具	Stacker arm cylinder supporting braket	1				
S 32	6056	段付ネジ	Screw	1				
S 33	N006	ナット	Nut	1				
S 34	6019	スタッカー腕作動シャフト土台メタル	Base	2				
S 35	M825	止めネジ	Screw	4				
S 36	SW08	スプリングワッシャー	Spring washer	4				
S 37	W0B8	ワッシャー	Washer	4				
S 38	6013	スタッカー腕作動シャフト	Shaft	1				
S 39	6011	スタッカー腕止金具	Stacker arm set base	1				
S 40	M815	止めネジ	Screw (for Fig.39)	2				
S 41	6010	リミットスイッチ当て板金具	Switch activation plate set base	1				
S 42	M815	止めネジ	Screw (for Fig.41)	1				
S 43	6012	リミットスイッチ当て板	Switch activation plate	1				
S 44	M515	止めネジ	Screw	2				
S 45	SW05	スプリングワッシャー	Spring washer	2				
S 46	W005	ワッシャー	Washer	2				
S 47	6018	リミットスイッチ取付板	Limit switch set plate	1				
S 48	M435	スイッチ止めネジ	Screw (for limit switch)	2				
S 49	SW04	スプリングワッシャー	Spring washer	2				
S 50	W004	ワッシャー	Washer	2				

Fig. No.	部品番号 Parts. No.	部 品 名	Description	個・台 Amt. Req.	共通部品 Common Parts			
S51	N004	ナット	Nut	2				
S52	5023	スタッカー用テーブル補助板	Plate	1				
S53	M410H	止めネジ	Screw	3				
S54	SW04	スプリングワッシャー	Spring washer	3				
S55	W004	ワッシャー	Washer	3				
S56	6003	スタッカー腕	Arm	1				
S57								
S58								
S59								
S60	6051	スタッカー本体 (スラックス用)	Stacker base (for slacks)	1				
S61	6052	布裁き棒	Material treating bar	1				
S62	6052-1	布押え棒	Material clamp bar	1				
S63	6053	布押え棒作動棒	Operating bar (for Fig.63)	1				
S64	6054	布裁き棒,布押え棒止金具土台	Base	4				
S65	M820	止めネジ	Screw (for Fig.64)	8				
S66	SW08	スプリングワッシャー	Spring washer	8				
"	W008	ワッシャー	Washer	8				
S67	6055	布裁き棒,布押え棒止金具	Base (for Fig.61,62)	4				
"	M510	" " 止ネジ	Screw	8				
S68	6056	段付ネジ	Pin screw (for Fig.67)	4				
S69	N010	ナット	Nut	4				
S70	SW10	スプリングワッシャー	Spring washer	4				
S71	W010	ワッシャー	Washer	4				
S72	6057	布裁き,布押えシリンダー止土台	Cylinder base	2				
S73	M820	止めネジ	Screw	2				
S74	SW08	スプリングワッシャー	Spring washer	2				
S75	W008	ワッシャー	Washer	2				
S76	6058	布裁き,布押えシリンダー止ピンネジ	Cylinder set pin screw	2				
S77	6062	布裁きシリンダー先端金具止土台	Set brock	1				
S78	M625	止めネジ	Screw (for Fig.77)	2				
S79	6059	布裁きシリンダー先端金具	Cylinder supporting braket	1				
S80	6060	段付ネジ	Pin screw (for Fig.79)	1				
S81	6063	エアスイッチ当て板止土台	Air switch activation plate base	1				
S82	W625	止めネジ	Screw (for Fig.81)	2				
S83	6064	エアスイッチ当て板	Air switch activation plate	1				
S84	M515	止めネジ	Screw (for Fig.83)	2				
S85	SW05	スプリングワッシャー	Spring washer	2				
S86	W005	ワッシャー	Washer	2				
S87	6067	布押えシリンダー止土台取付板	Set plate	1				
S88	M820	止めネジ	Screw	2				
S89	SW08	スプリングワッシャー	Spring washer	2				
S90	W008	ワッシャー	Washer	2				
S91	6061	布押えシリンダー先端金具	Supporting braket	1				
S92	6065	" カラー	Collar	2				
S93	M510	止めネジ	Screw (for Fig.92)	2				
S94	6068	布裁き補助用空気パイプ	Air pipe	1				
S95	M510	止めネジ	Screw (for Fig.94)	2				
S96	6069	布裁き補助用空気パイプ止金具	Set brok	2				
S97	MSW2	丸平ネジ	Screw (for Fig.96)	2				
S98	5022	スタッカー用テーブル補助板	Plate	1				
S99	M410H	止めネジ	Screw	3				
S100	SW04	スプリングワッシャー	Spring washer	3				
S101	W004	ワッシャー	Washer	3				

エアシリンダー機構 (C)  
 Air cylinder mechanism

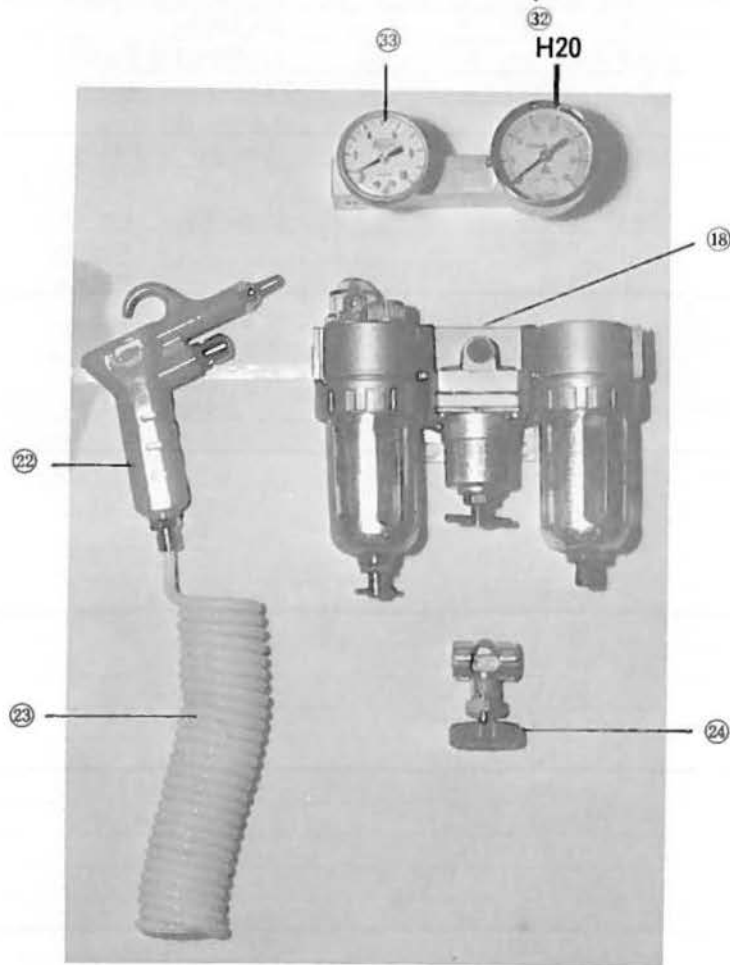
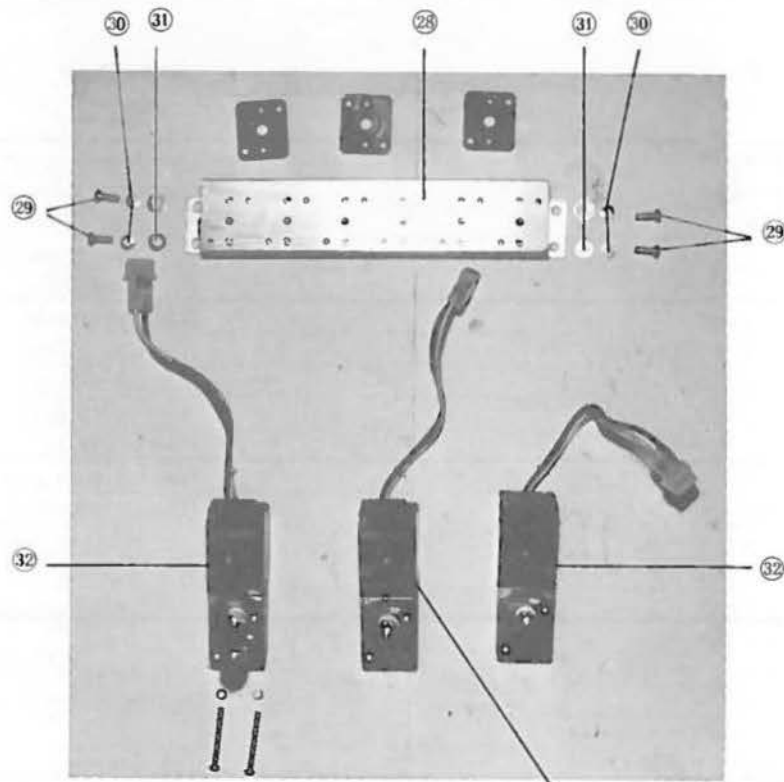

Fig. No.	部品番号 Parts. No.	部 品 名	Description	個・台 Amt. Req.	共通部品 Common Parts			
C 1	7001	上糸調節器シリンダー	Air cylinder(for thread tension regulator)	1				
C 2	7002	上糸緩めシリンダー	" (for upper thread releaser)	1				
C 3	7003	下糸切シリンダー	" (for lower thread knife)	1				
C 4	7004	上糸引掛けシリンダー	" (for upper thread holder)	1				
C 5	7005	センターメスシリンダー	" (for center knife)	1				
C 6	7006	折り込み板シリンダー	" (for folder blade)	2				
C 7	7007	フラップ押えシリンダー	" (for flap clamp)	2				
C 8	7008	大押えシリンダー	" (for main clamp)	2				
C 9	7009	T型シリンダー	" (for patch guide)	1				
C10	7010	コーナメスシリンダー	" (for tab knife)	1				
C11	7011	コーナメス位置決めシリンダー	" (for tab knife position adjusting)	1				
C12	7012	袋押えシリンダー	" (for strip holder)	1				
C13	7013	スタッカー左右シリンダー(上着用)	" (for coat stacker)	1				
C14	7014	スタッカー布つかみシリンダー(上着用)	" (for material grasping)	1				
C15	7015	スタッカー布つかみ左右シリンダー(上着用)	" (for material grasping left or right)	1				
C16	7016	スタッカー左右シリンダー(スラックス用)	" (for pants)	1				
C17	7017	スタッカー布捌きシリンダー	" (for material holder)	1				
C18	7030	三点セット	Supply air filter/Regulator/Lubricator assembly	1				
C19	7031	ストップバルブ(3V)	Stop valve	4				
C20	7032	スタッカー用エアースイッチ	Air switch(for stacker)	1				
C21	7033	袋押え用エアースイッチ	Air switch(for strip holder)	1				
C22	7034	エアダスター	Air duster	1				
C23	7035	エアダスターホース	Air hose(for Fig.22)	1				
C24	7036	ストップ弁	Stop valve	1				
C25	7037	エアーマフラー	Air muffler	6				
C26	7038	スピードコントローラー	Speed control valve	8				
C27	7039	" (L型)	" (L type)	4				
C28	7040	マニホールド 2連	Manifold 2 stations	1				
"	7040-1	" 6連	" 6 stations	1				
"	7040-2	" 7連	" 7 stations	1				
C29	M410	止めネジ	Screw	6				
C30	SW04	スプリングワッシャー	Spring washer	6				
C31	W004	ワッシャー	Washer	6				
C32	7041	電磁弁 050E1	Air solenoid valve 050E1	5				
"	7041-1	" 050E1-11	" 050E1-11	1				
"	7041-2	" 050-4E1	" 050-4E1	9				
C33	7042	エア圧力計	Air pressure gage	1				
C34	7060	継手 5M×4A	Joint 5M×4A	3				
C35	7061	" 5Mユニバーサル	" 5M	6				
C36	7062	" 5M×6A	" 5M×6A	12				
C37	7063	" 5Mホースニップル	" 5M hose					
C38	7064	" 1/8×4A	" 1/8×4A	4				
C39	7065	" 1/8×4B	" 1/8×4B	1				
C40	7066	" 1/8×6A	" 1/8×6A	43				
C41	7067	" 1/8×6B	" 1/8×6B	17				
C42	7068	" 1/4×6A	" 1/4×6A	1				
C43	7069	" 1/4×6B	" 1/4×6B					
C44	7070	" 1/4×10A	" 1/4×10A	1				
C45	7071	" 1/4×10B	" 1/4×10B	3				
C46	7075	ニップル 1/4 (六角真鍮)	Nipple 1/4	2				
C47	7076	チーズ 1/8 (真鍮)	Tee 1/8	2				
C48	7077	ソケット 1/8 (六角真鍮)	Socket 1/8	1				
C49	7078	" 1/4 ( " )	" 1/4	2				
C50	7079	ニップル 1/8 ( " )	Nipple 1/8	2				
C51	7080	チーズ 1/8	Tee 1/8	2				

Fig. No.	部品番号 Parts. No.	部品名 Part Name		Description	個・台 Amt. Req.	共通部品 Common Parts			
C52	7081	チーズ	1/4	Tee	1/4				
C53	7082	ニップル	1/4 六角	Nipple	1/4				
C54	7083	"	1/8	"	1/8				
C55	7084	エルボ	1/8	Elbow	1/8				
C56	7085	プラグ	1/8	Plug	1/8				
C57	7086	"	1/4	"	1/4				
C58	7087	ブッシング	1/4 x 1/8	Bushing	1/4 x 1/8				
C59	7088	ストリートエルボ	1/8 x 1/8	Street elbow	1/8 x 1/8				
C60	7089	ホース	4φ (黒)	Air tube	4φ (black)				
"	7090	"	4φ (黄)	"	4φ (yellow)				
C61	7091	"	6φ (黒)	"	6φ (black)				
"	7092	"	6φ (黄)	"	6φ (yellow)				
C62	7093	"	10φ (黒) デカボン	"	10φ (black)				

油压机构  
Hydraulic mechanism

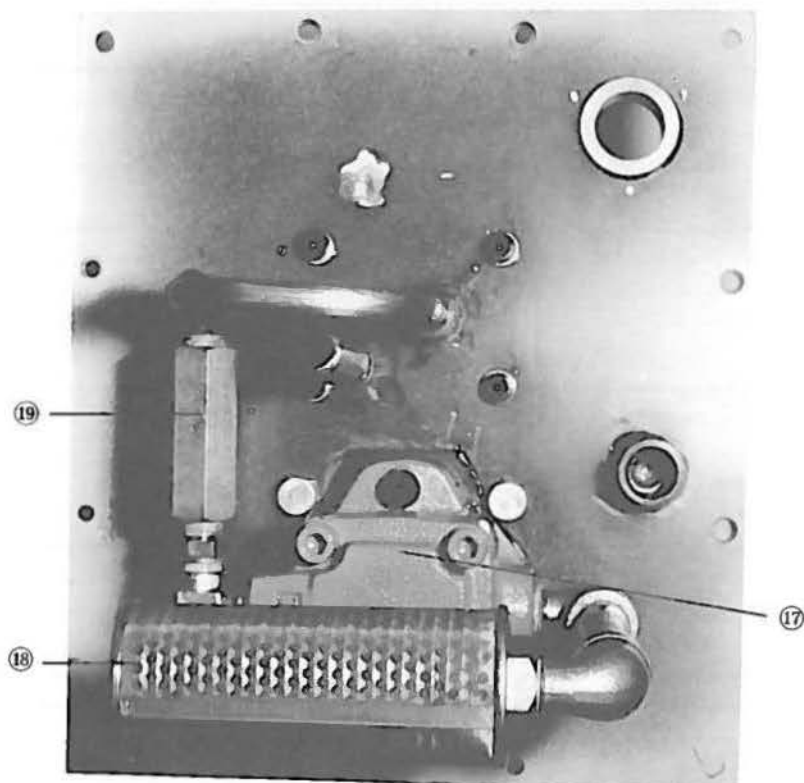
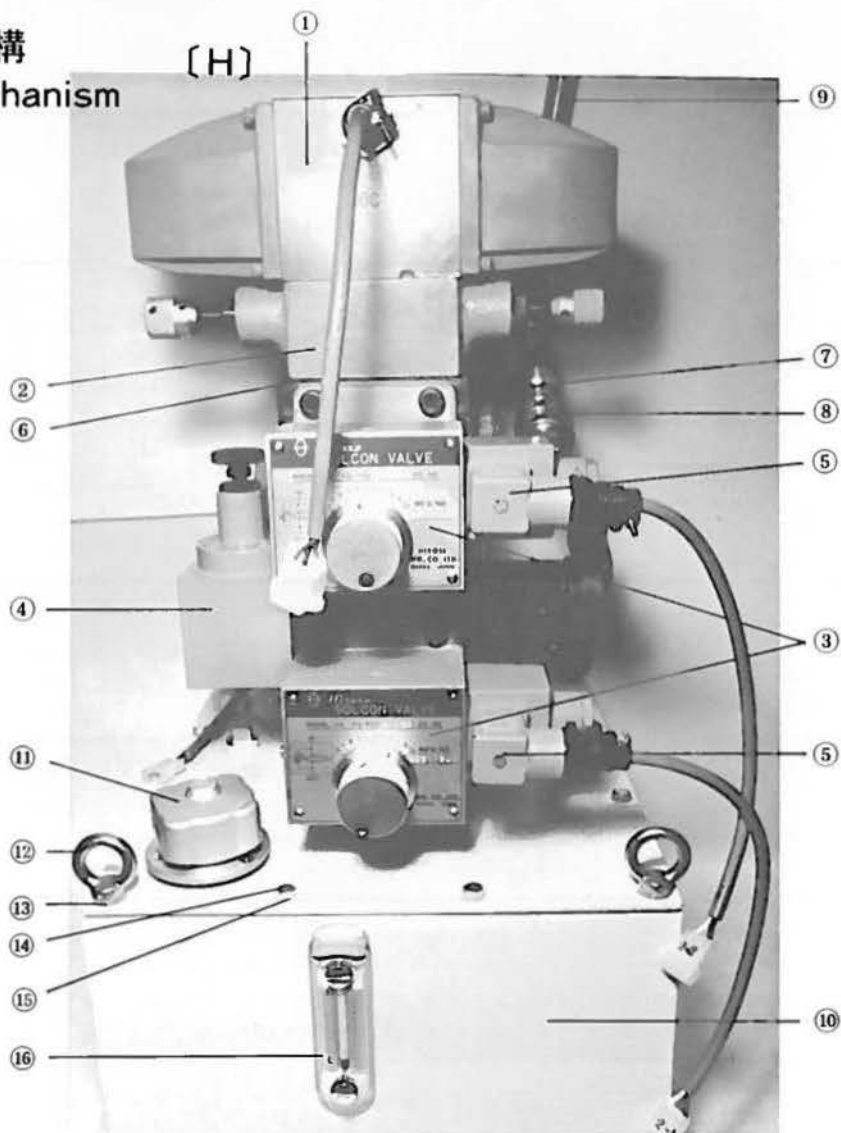
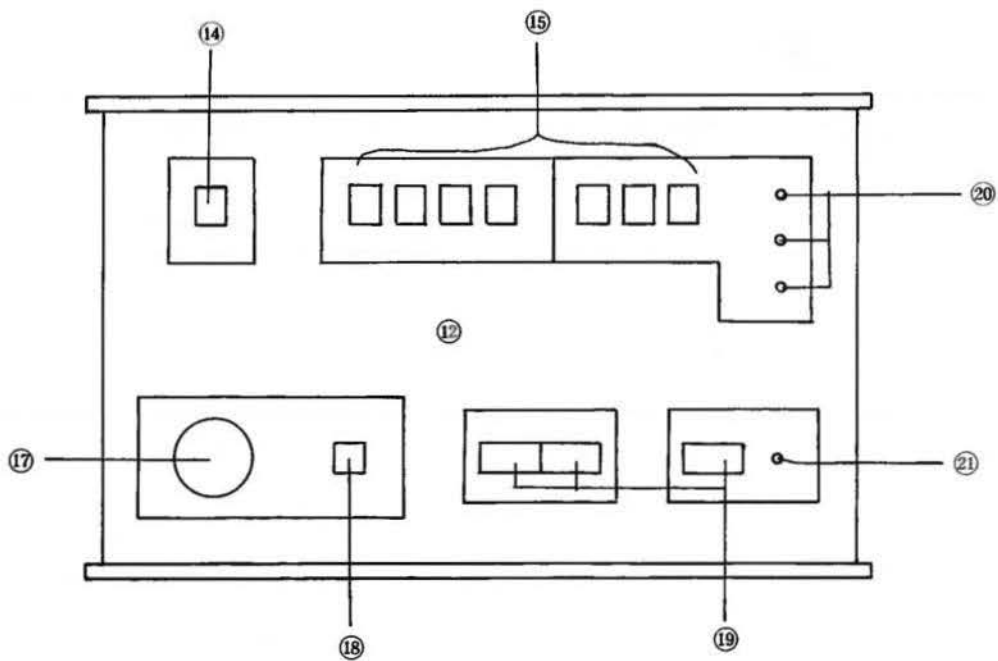
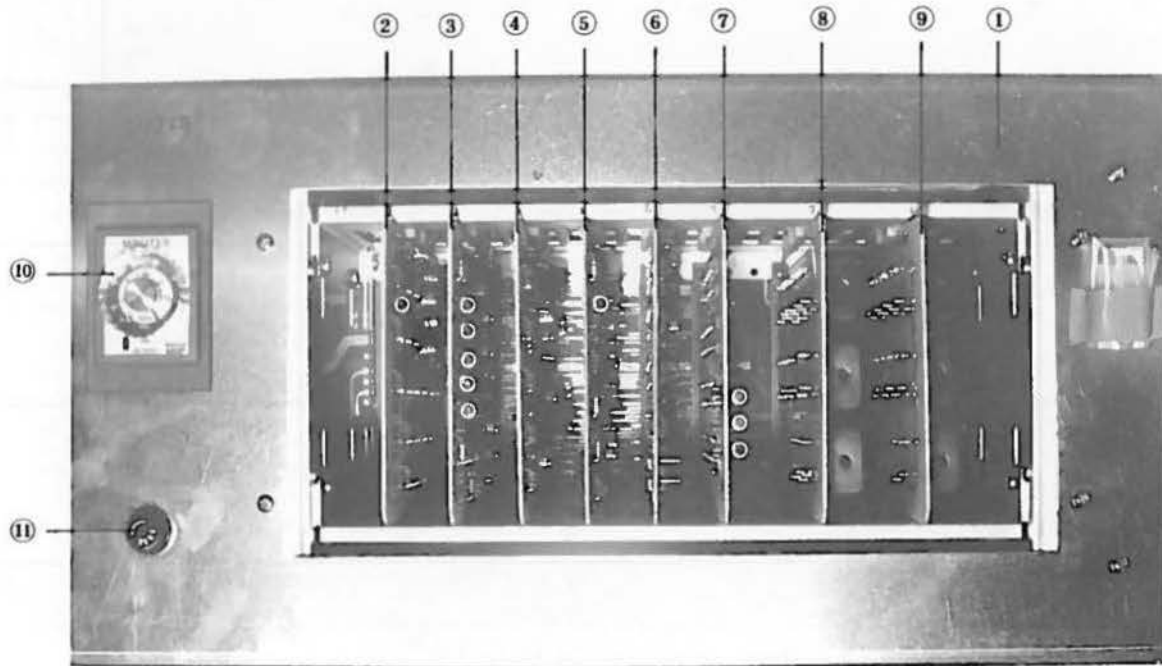

Fig. No.	部品番号 Parts. No.	部 品 名	Description	個・台 Amt. Req.	共通部品 Common Parts			
H 1	8001	電磁操作弁	Solenoid valve	1				
H 2	8002	流量絞り弁	Slotle check valve	1				
H 3	8003	ソルコン	Solcon valve	2				
H 4	8004	圧力制御弁	Relief valve	1				
H 5	8003-1	ソルコン用コネクター	Connector (for Fig. 3)	2				
H 6	8005	モーター	Pump drive motor	1				
H 7	8007	マニホールド	Manifold block	1				
H 8	8008	カプラー	Joint	2				
H 9	8009	油圧ホース	Hydraulic hose	2				
H10	8010	オイルタンク	Oil tank	1				
H11	8011	注油口キップ, エア-取入口	Oil filler cap/Air breezier	1				
H12	M810	アイボルト	"I" bolt	4				
H13	WON8	ナイロンワッシャー	Nylon washer	4				
H14	M615	ボルト	Bolt	8				
H15	WON6	ナイロンワッシャー	Nylon washer	8				
H16	8012	温度計付油面計	Oil level/Temperature gage	1				
H17	8013	オイルポンプ	Oil pump	1				
H18	8014	サクションストレーナー	Suction strainer	1				
H19	8015	インラインチェックバルブ	Inline check valve	1				
H20	8016	油圧計	Oil pressure gage	1				
H21	8017	油圧シリンダー	Hydraulic cylinder	1				
H22	8018	油圧シリンダー継手	Joint (for hydraulic cylinder)	2				

電氣關係 (E)  
 Electric mechanism





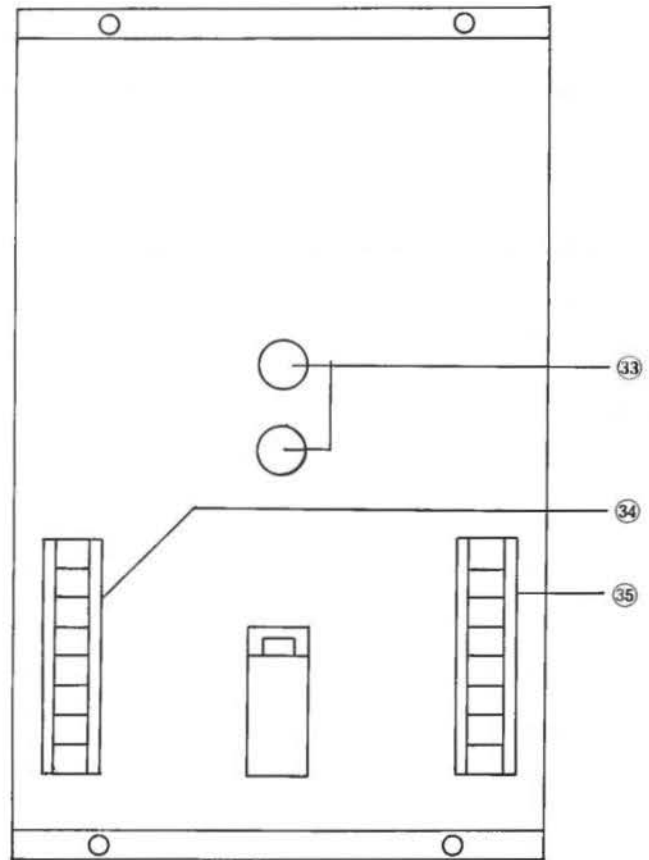
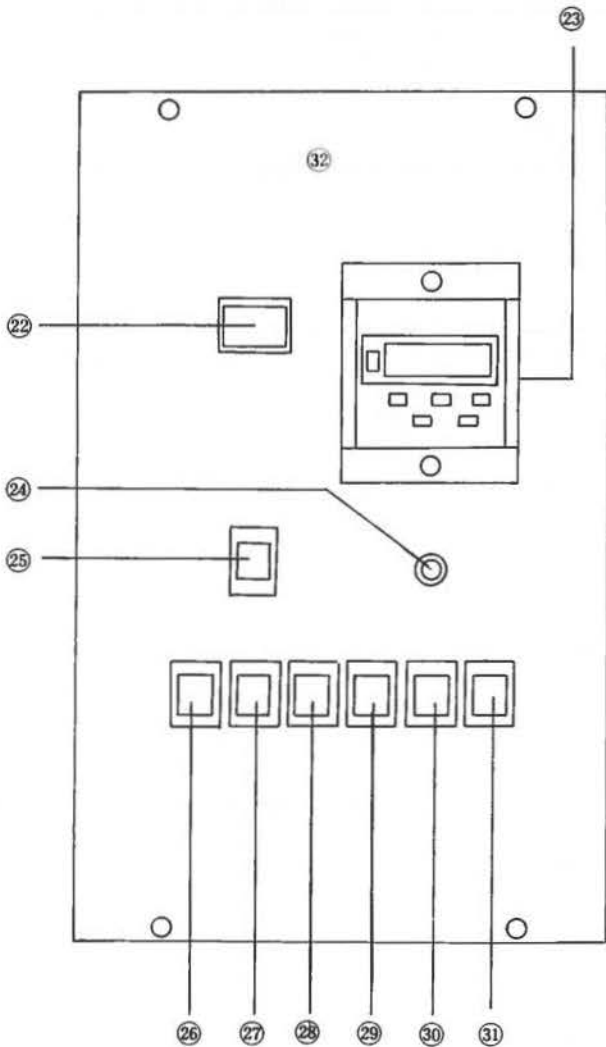
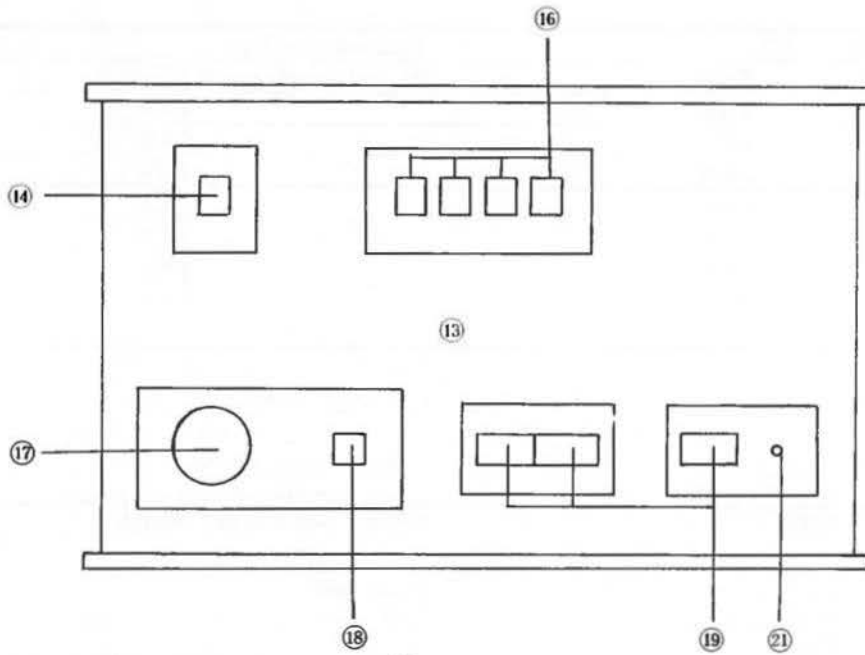

Fig. No.	部品番号 Parts. No.	部 品 名	Description	個・台 Amt. Req.	共通部品 Common Parts			
E 1	9001	制御ボックス	Main control box	1				
E 2	9002	基板 PKN-1	Printed circuit board PKN-1	1				
E 3	9003	" PKN-2	" PKN-2	1				
E 4	9004	" PKN-3	" PKN-3	1				
E 5	9005	" PKN-4	" PKN-4	1				
E 6	9006	" PKN-5	" PKN-5	1				
E 7	9007	" PKN-6	" PKN-6	1				
E 8	9008	" PKN-7	" PKN-7	1				
E 9	9009	" PKN-9	" PKN-9	1				
E10	9010	空運転タイマー	Free run timer	1				
E11	9011-3	ヒューズ (3A)	Fuse 3A(for main control)	1				
E12	9012-F	操作ボックスA フラップ用	Operation box(A) with flap	1				
E13	9012	" フラップなし用	" (A) with out flap	1				
E14	9013	上糸切スイッチ	Upper thread trimmer switch	1				
E15	9014-F	縫寸法,フラップ連動スイッチ	Sewing length/Flap select switch	1				
E16	9014	縫寸法連動スイッチ	Sewing length select switch	1				
E17	9015	非常停止スイッチ	Emergency stop switch	1				
E18	9016	リセットスイッチ	Reset switch	1				
E19	9017	手動,自動連動スイッチ	Manual/Automatic select switch	1				
E20	9018	光電管確認ランプ	Photocell confirmation lamp	1				
E21	9019	自動運転確認ランプ	Operation starting lamp	1				
E22	9020	電源スイッチ	Power supply switch	1				
E23	9021	下糸減算カウンター	Counter	1				
E24	9022	カウントアウトランプ	Count out lamp	1				
E25	9023	ステッチ選択スイッチ	Stitch select switch	1				
E26	9024	ミシンスイッチ	Sewing machine switch	1				
E27	9025	センターメススイッチ	Center knife switch	1				
E28	9026	コーナメススイッチ	Tab knife switch	1				
E29	9027	スタッカースイッチ	Stacker switch	1				
E30	9028	位置決めランプスイッチ	Position lamp switch	1				
E31	9029	空運転スイッチ	Free run switch	1				
E32	9030	操作ボックスB	Opraton box (B)	1				
E33	9011-0	ヒューズ (10A)	Fuse 10A (for power supply)	2				
E34	9031	端子台 (A)	Trminal base (A)	1				
E35	9031-1	" (B)	" (B)	1				
E36	9032	マーキングランプセット	Marking lamp set	2				
E37	9032-B	マーキングランプ球	Marking lamp bulb	2				
E38	9033	光電管	Photocell	2				
E39	9033-T	反射テープ	Reflective tape	12				
E40	9034	センターメス安全スイッチ	Center knife safety switch	1				
E41	9035	フットリミットスイッチ (S1~S3)	Foot limit switch(S-1~S-3)	3				
E42	9036	フットスイッチ (S4)	Foot switch (S-4)	1				
E43	9037	リミットスイッチ(L-1~L-3,L-5~L-7)	Cramp-travel limit switch(L-1 L-3,L-5 L-7)	11				
E44	9038	コーナメス上下確認スイッチ(L-8,L-9)	Tab knife limit switch	2				
E45	9039	" 位置決めリミットスイッチ(L-10)	Tab knife position adjusting limit switch(L-10)	1				
E46	9040	スタッカースイッチ(L-12)	Stacker limit switch (L-12)	1				



